

# بِسْمِ اللّٰهِ الرَّحْمٰنِ الرَّحِیْمِ

*Work team:*

*Merna Waheeb Ablhud*

*Manar Abd-ul-Rahma*

**Meena Abd-ul-Fattah Noori**

*Meelad Waleed Aboody*

*Mina Amir Betrous*

\*\*\*\*\*

*supervised by: Prof. Ahmed Yahya Dallal Bashi*

# Carnitine

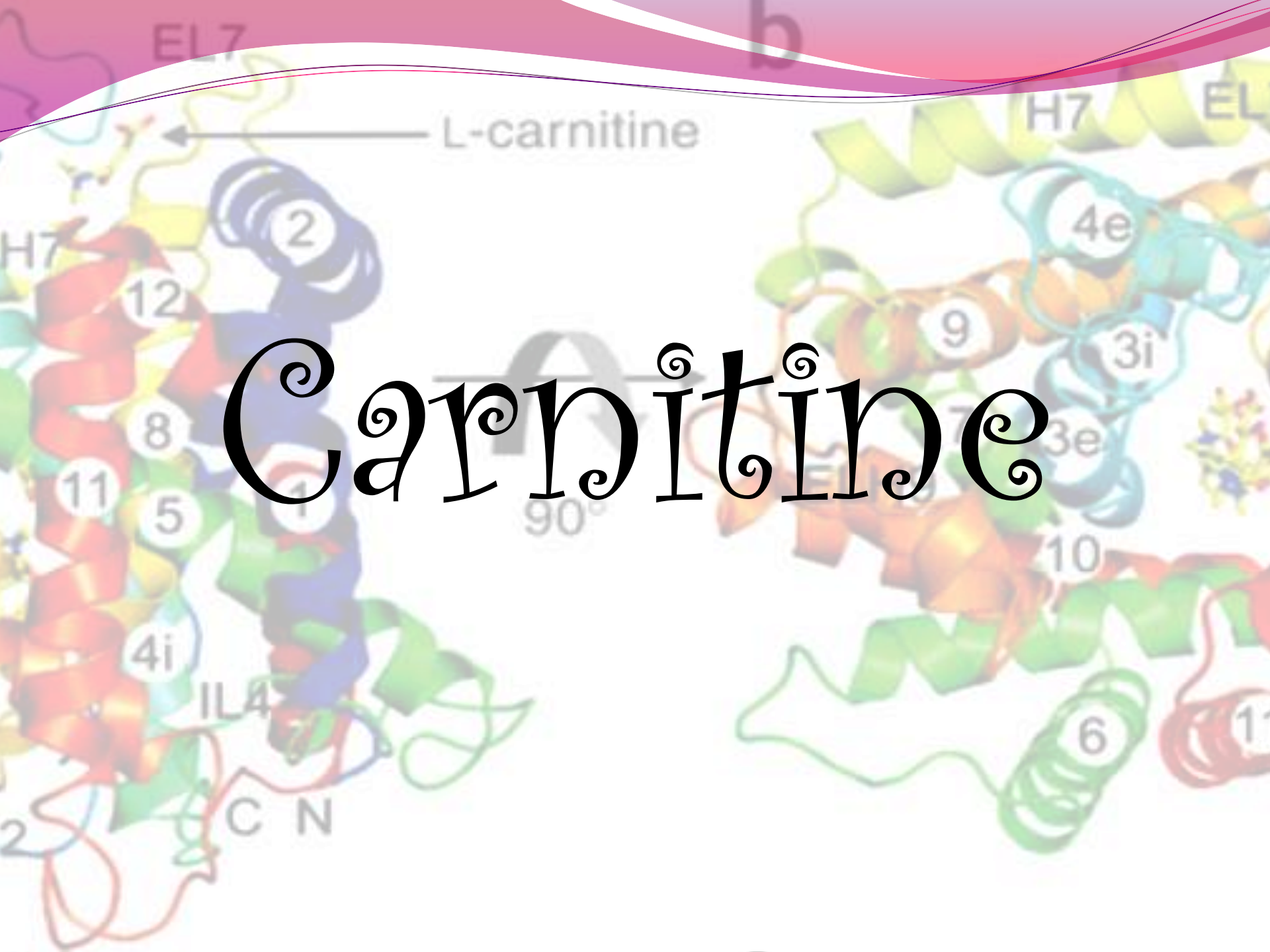

# Objectives:

- ❖ Carnitine.
- ❖ The relationship of carnitine and diseases including:
  - ❖ Obesity
  - ❖ Type 2 diabetes
  - ❖ Cancer
  - ❖ Cardiovascular diseases
  - ❖ Thalassemia.

# *Carnitine*

❖ Carnitine, the L-beta-hydroxy-gamma-N-trimethyl amino butyric acid, is a quaternary ammonium compound is found in nearly all cells of the body.

❖ In animals, the biosynthesis of carnitine occurs primarily in the liver, kidney and brain, from the essential amino acids lysine and methionine and Vitamin C (ascorbic acid). Ferrous ion, pyridoxine (Vit. B6), niacin Vit. B3) are also necessary cofactors.

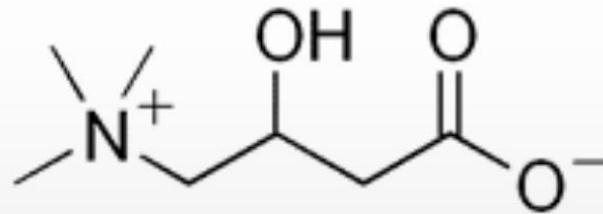
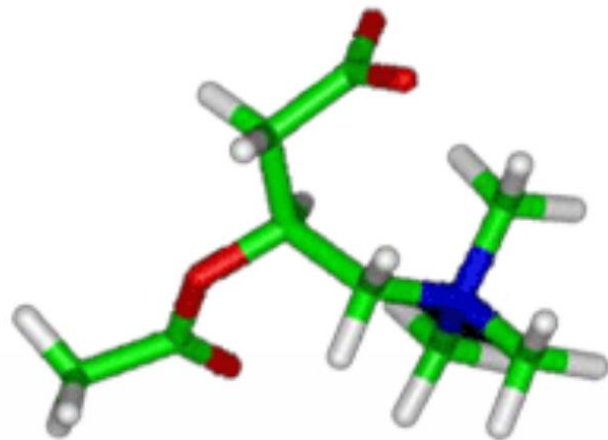

L-Carnitine



❖ There are three different forms of carnitine:

1. L-carnitine
2. acetyl-L-carnitine
3. propionyl-L-carnitine

L-Carnitine

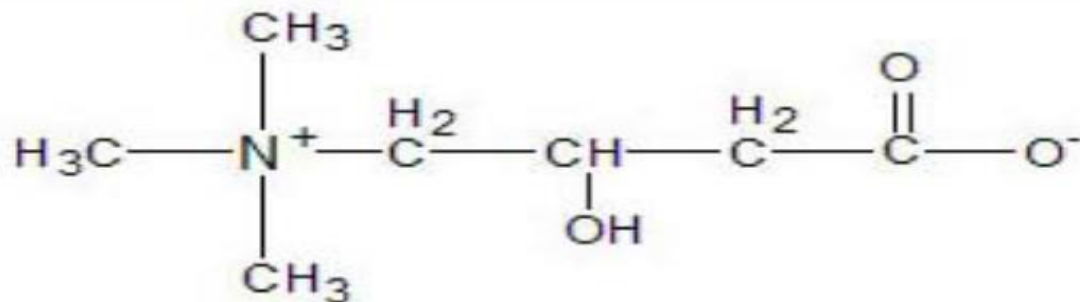

Acetyl-L-Carnitine

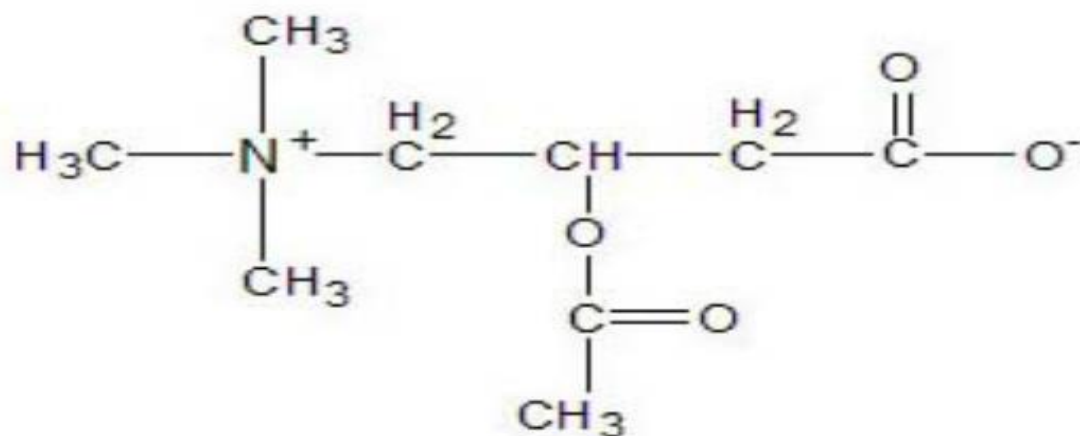

Propionyl-L-Carnitine

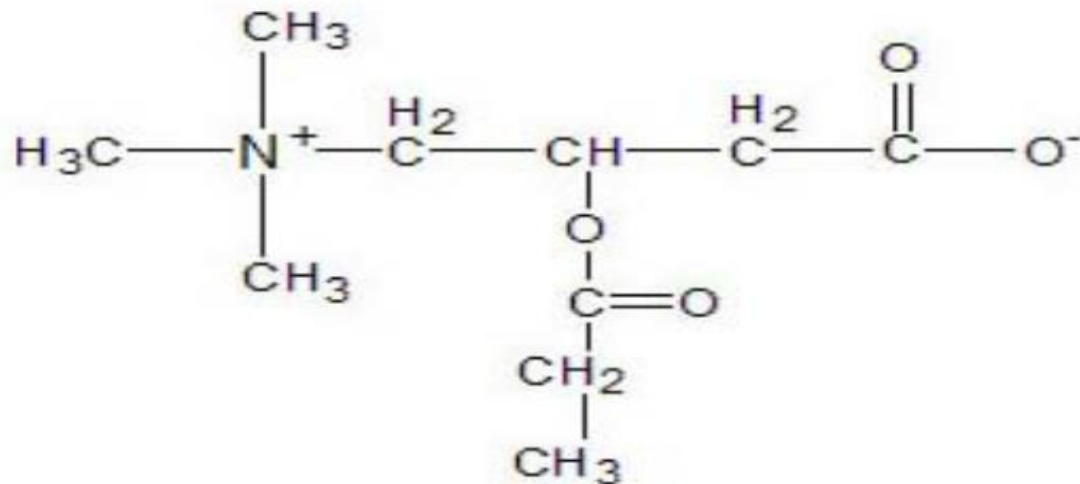

❖ It plays a critical role in energy production; It transports long-chain fatty acids into the mitochondria so they can be oxidized ("burned") to produce energy. It also transports the toxic compounds generated out of this cellular organelle to prevent their accumulation

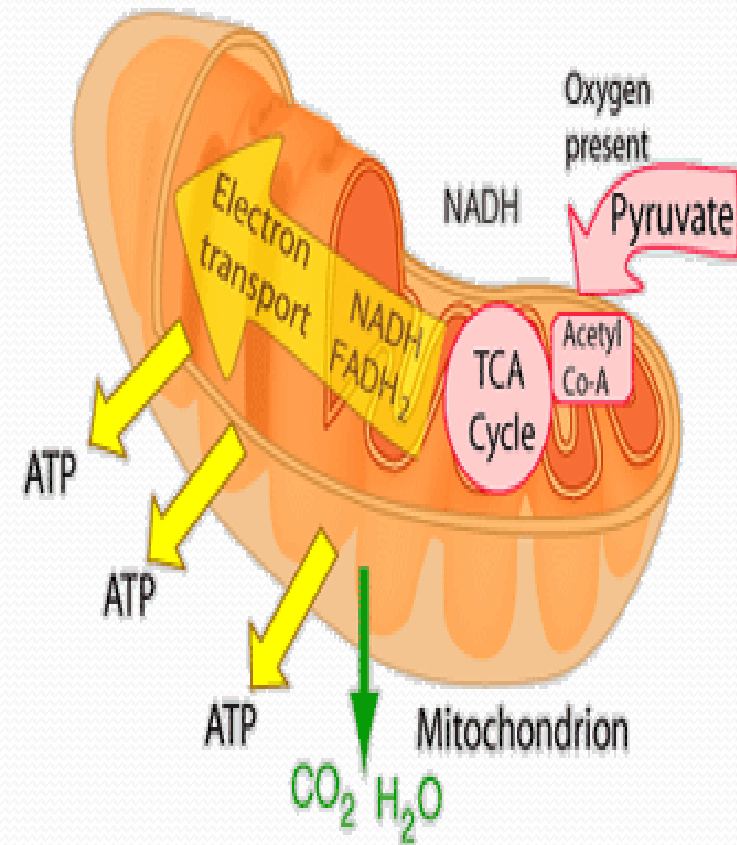



- 
- ❖ Given these key functions, carnitine is concentrated in tissues like skeletal and cardiac muscle that utilize fatty acids as a dietary fuel.
  - ❖ Healthy children and adults do not need to consume carnitine from food or supplements, as the liver and kidneys produce sufficient amounts from the amino acids **lysine** and **methionine** to meet daily needs.

- 
- ❖ In the course of human aging, carnitine concentration in cells diminishes, affecting fatty acid metabolism in various tissues, particularly bones (which require continuous reconstructive and metabolic functions of osteoblasts for maintenance of bone mass), the myocardial and endothelial cell level.
  - ❖ studies suggests that supplements of acetyl-L-carnitine may improve mental function and reduce deterioration in older adults with mild cognitive impairment and Alzheimer's disease.

# Role in fatty acid metabolism:

- ❖ Carnitine transports long-chain acyl groups from fatty acids into the mitochondrial matrix, so they can be broken down through  $\beta$ -oxidation to acetyl CoA to obtain usable energy via the citric acid cycle.
- ❖ Fatty acids must be activated before binding to the carnitine molecule to form 'acyl carnitine'. The free fatty acid in the cytosol is attached with a thio ester bond to coenzyme A (CoA).

- 
- ❖ This reaction is catalyzed by the enzyme fatty acyl-CoA synthetase and driven to completion by inorganic pyrophosphatase.
  - ❖ The acyl group on CoA can now be transferred to carnitine and the resulting acyl carnitine transported into the mitochondrial matrix. This occurs via a series of similar steps:

- ❖ Acyl CoA is transferred to the hydroxyl group of carnitine by carnitine acyl transferase I (palmitoyl transferase) located on the outer mitochondrial membrane
- ❖ Acyl carnitine is shuttled inside by a carnitine-acyl carnitine translocase
- ❖ Acyl carnitine is converted to acyl CoA by carnitine acyl transferase II (palmitoyl transferase) located on the inner mitochondrial membrane. The liberated carnitine returns to the cytosol.

CYTOSOL

Acyl-CoA from cytosol to the mitochondrial matrix

MATRIX

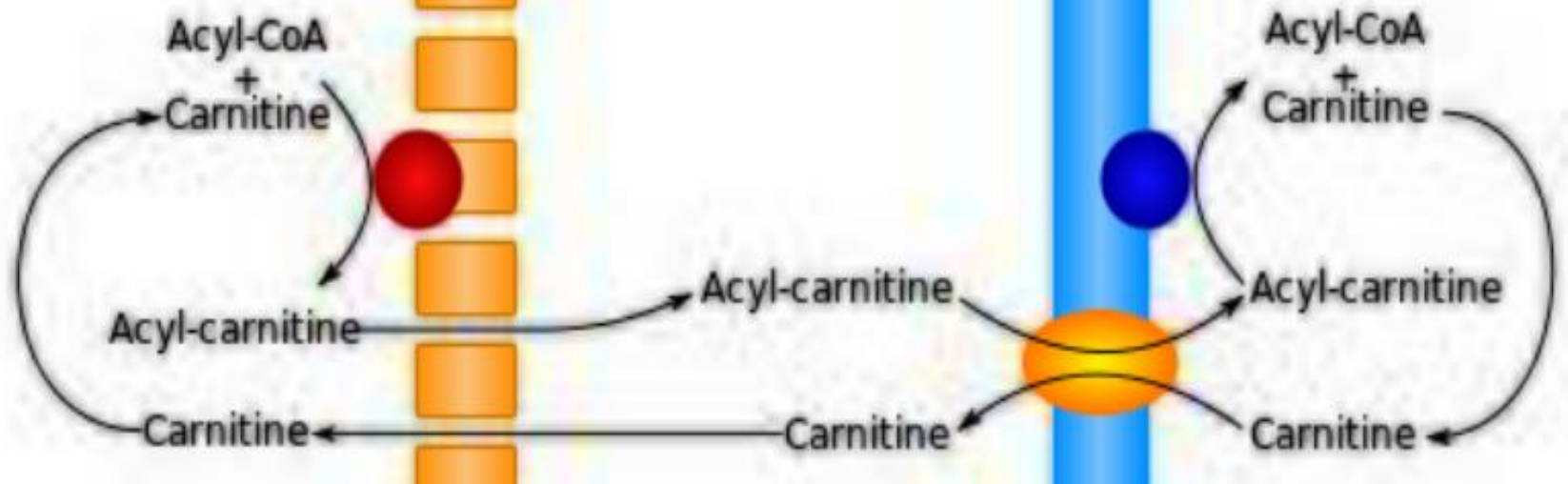

 CPTI (Carnitine Palmitoyl Transferase I)

 Translocase

 CPTII (Carnitine Palmitoyl Transferase II)

# Absorption and metabolism

Adults eating mixed diets gets about 60–180 milligrams of carnitine.

Vegans get considerably less (about 10–12 milligrams) since they avoid animal-derived foods and other animal products.

Most dietary carnitine (54–86%) is absorbed in the small intestine and enters the bloodstream.

The kidneys efficiently conserve carnitine



## When carnitine deficiency may occur?

❖ **Two** types of carnitine deficiency states exist:

- **Primary carnitine deficiency:**

is a genetic disorder of the cellular carnitine-transporter system that usually manifests itself by five years of age with symptoms of cardiomyopathy, skeletal muscle weakness, and hypoglycemia. Some individuals (such as preterm infants), cannot make enough, so for them carnitine is a conditionally essential nutrient.





- **Secondary carnitine deficiencies :**

Are characterized by increased carnitine in urine in the form of acyl-carnitine. It can be caused by pharmacological therapy, inherited metabolic disorders, poor diet or mal absorption. Certain disorders (such as chronic renal failure) or under particular conditions e.g. use of certain antibiotics that reduce carnitine absorption or increase its excretion .

There is scientific agreement on carnitine's value as a prescription product for treating such deficiencies.

# Side effects and precautions

Taking carnitine supplements should be supervised by a doctor, especially if the patient suffering from the following conditions:

- ❖ Diabetes
- ❖ Kidney diseases
- ❖ High blood pressure
- ❖ Cirrhosis

Carnitine may lead to the following side effects:

Diarrhea, Increased appetite, Rash.

- ❖ Are there health risks from too much carnitine?
- ❖ At doses of approximately 3 g/day, carnitine supplements can cause nausea, vomiting, abdominal cramps, diarrhea, and a "fishy" body odor . Rarer side effects include muscle weakness in uremic patients and seizures in those with seizure disorders.

# Carnitine and Obesity

Visceral belly fat is one of the toughest fats to lose once you've got it, and it causes numerous health problems. Once you begin to gain visceral fat around the belly, it will lead to fat gain within the organs such as the liver, the heart, or even in muscle. Fat gain in the liver leads to non-alcoholic fatty liver disease, while epicardial fat is a type of visceral fat that is deposited around the heart and is considered a metabolically active organ, altering heart function.

- 
- Raising carnitine levels uptake will fight this visceral fat gain because it increases fat burning, which has the effect of taking triglycerides and low-density lipoproteins out of the system so that they decrease levels of cholesterol and atherosclerosis

- A study published in the Journal Food and Chemical Toxicology illustrates that when carnitine supplement is given to mice who were fed a high-fat diet in order to make them gain weight and compared with a group of mice fed without carnitine, the carnitine group gained substantially less visceral and subcutaneous fat.
- Moreover, the group that not given carnitine exhibited the beginning stages of non-alcoholic fatty liver disease and atherosclerosis, neither of which were evident in the carnitine group.

# How carnitine decrease weight?

- Carnitine, by stimulating beta-oxidation, reduces the utilization of the branch chain amino acids, which if decreased result in reducing lean body mass rather than fat.
- induce appetite suppression.

- 
- A study conducted in 1992 evaluated 40 obese individuals from 19-68 years old over an 8-weeks period. They were given 200 mg of Carnitine they showed a reduction in weight, body fat, LDL cholesterol and total cholesterol. They also noted feeling more energy, less hungry and fewer cravings for sugar allowing them to stay on the diet more easily.



- Another study in 1998 on 100 obese people whom were given 4 grams of L-Carnitine per day for 4 weeks. They showed 25% loss in body weight. In addition had lower total cholesterol level, as well as lower LDL. The blood sugar and blood pressure levels were also lowered. ●

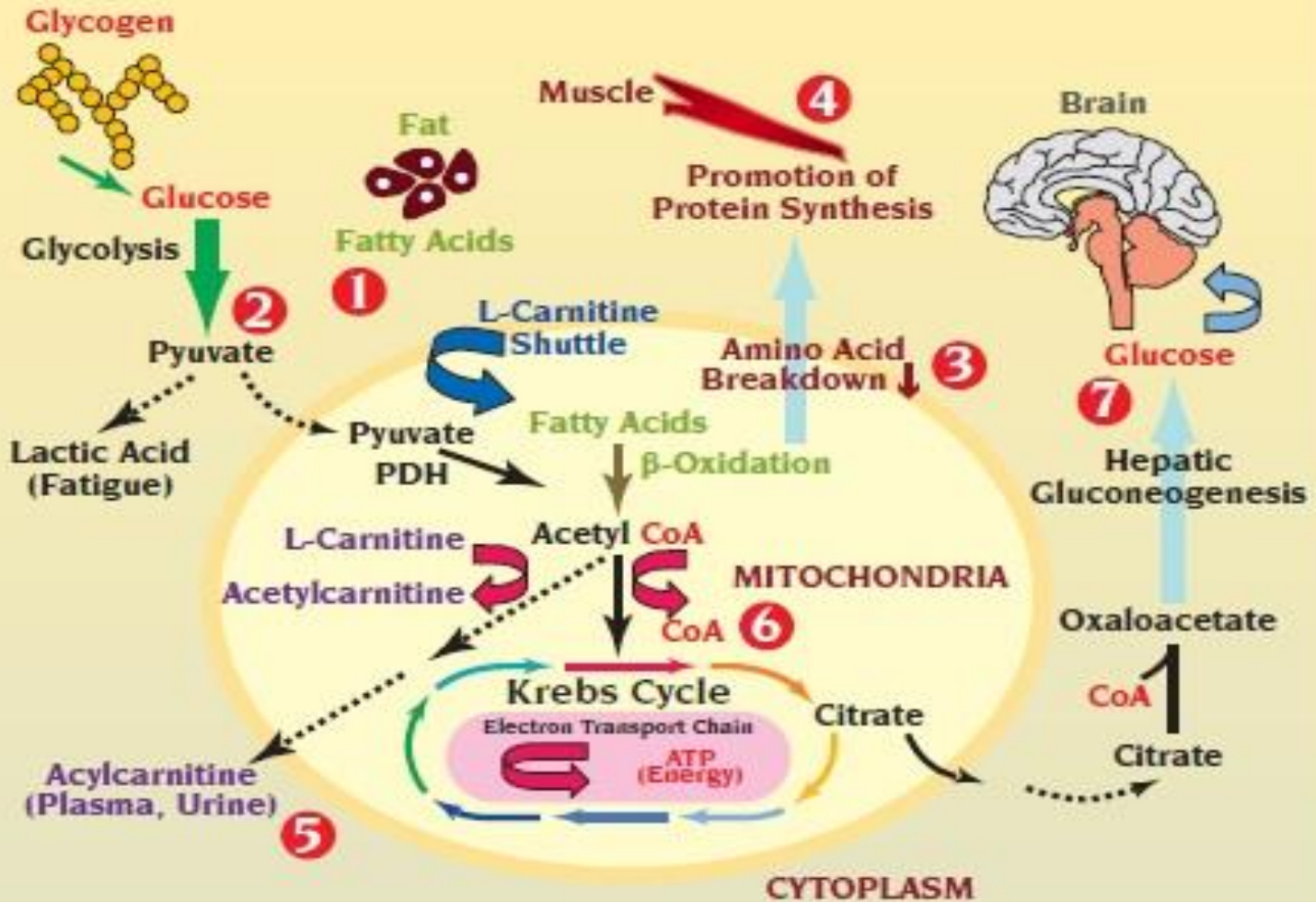

**Figure 4: Proposed mechanism of action of L-Carnitine for weight management.**

# Carnitine and Type 2 diabetes

- ❖ Diabetes is a disease characterized by abnormality in the metabolism of carbohydrate and fat. Type 2 diabetes is the most common type it occupies 95% of diagnosed diabetes.
- ❖ It is often associated with increased fatty acid triglyceride (TG) and non-esterified fatty acid (NEFA) level.

- 
- ❖ Pyruvate is a three carbon end product of the breakdown of glucose in glycolysis, then it will be converted to lactic acid.
  - ❖ When lactate level increase in type 2 diabetes carnitin administration will decrease lactate level this is may be due carnitine increase the activity of pyroovate dehydrogenase (which is the key enzyme for the aerobic oxidation of glucose in the mitochondria).

- ❖ Both glycolysis and fatty acid metabolism produce acetyl CoA . When acetyl CoA accumulate, it can inhibit pyruvate dehydrogenase (the enzyme responsible for producing acetyl CoA from pyruvate) .

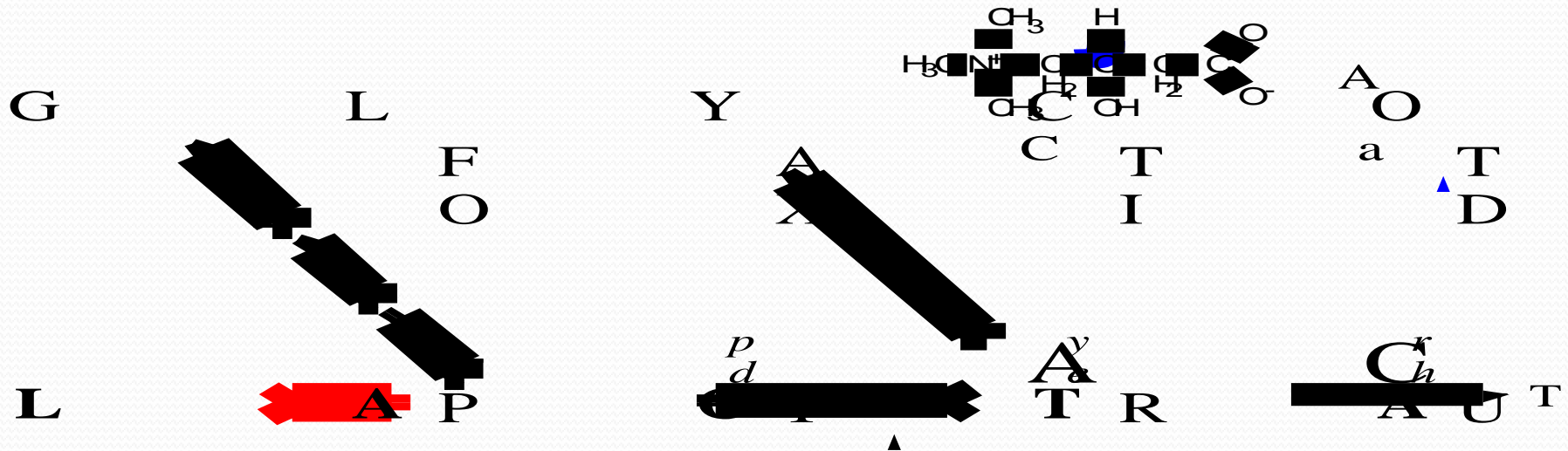

Stages in the extraction of energy from food stuffs.

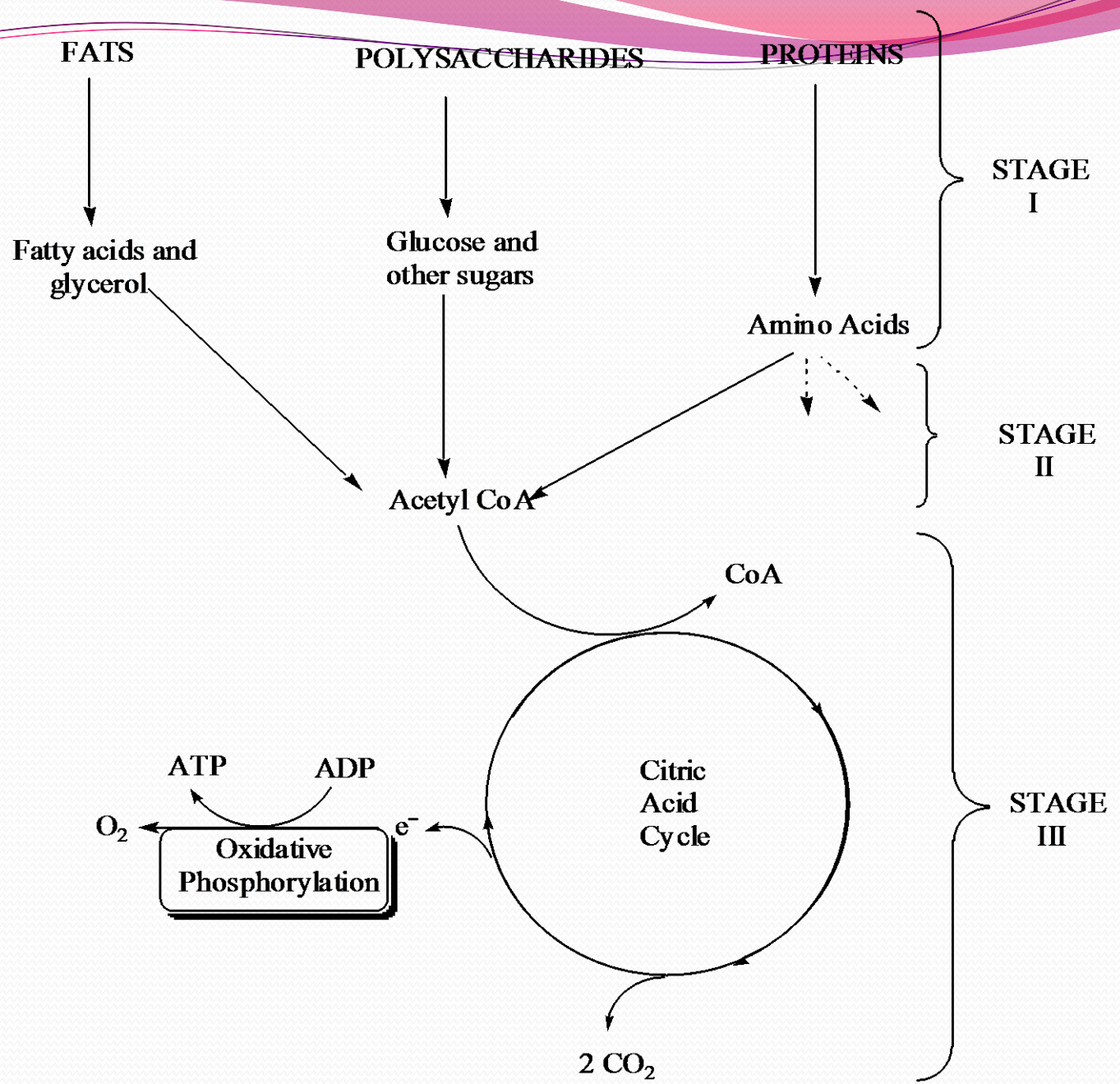



❖ Carnitine also affect the synthesise of the key enzyme for glycolysis (Hexokinase and Glucokinase) and gluconeogenesis. In this way it increase the sensitivity of insulin so it is used as therapeutic substance in patient with type 2 diabetes .

It is found that when L-carnitine is given in a dose of 2-3 g daily for patients with hyperlipidemia, lipid profile will be improved significantly.

❖ A recent analysis of two multicenter clinical trials of subjects with either type 1 or type 2 diabetes found that treatment with acetyl-L-carnitine (3 grams/day orally) for one year provided significant relief of nerve pain and improved vibration perception in those with diabetic neuropathy. The treatment was most effective in subjects with type 2 diabetes of short duration .



# Carnitine & cancer

- ❖ The study of carnitine system represents a tool to understand the molecular basis underlying in cancer cells.

# What is cancer?

- ❖ Medically known as a malignant neoplasm.
- ❖ It is a broad group of disease involving unregulated cell growth. Cancer cells divide and grow uncontrollably forming malignant tumors and invading nearby parts of the body.

# Carnitine & it's relation with cancer

- ❖ When carnitine became abnormally decreased whether in malignant or non malignant tissues ,reduction in B-oxidation of fatty acid will occur .

# The levels of serum carnitine in patients with cancer in digestive organs.

- ❖ Low serum level of carnitine in terminal neoplastic patients (gastrointestinal cancer) are decreased greatly due to decreased dietary intake and impaired endogenous synthesis of this substance. This low serum carnitine levels also contribute to progression of cachexia in cancer patients.

# Carntine & fatigue symptoms in patients with cancer

Fatigue is multi dimensional symptom that's described in terms of perceived energy, mental capacity and physiological status. It can impair daily functioning and lead to negative effect on quality of life.





Supplementation with carnitine experienced less fatigue and improve mood and quality of sleep.

Fatigue is one of the most common side effects of chemotherapy, radiotherapy and poor nutritional status in cancer patients.

In recent studies it is found that;

L-carnitine supplementation has been demonstrated to be able to improve fatigue symptoms in cancer patient's..



❖ Some important anti cancer drugs contribute to dysfunction of the carnitine system, which is reversed by carnitine treatment without affecting anti cancer therapeutic efficacy.

# Carnitine & Cardiovascular system

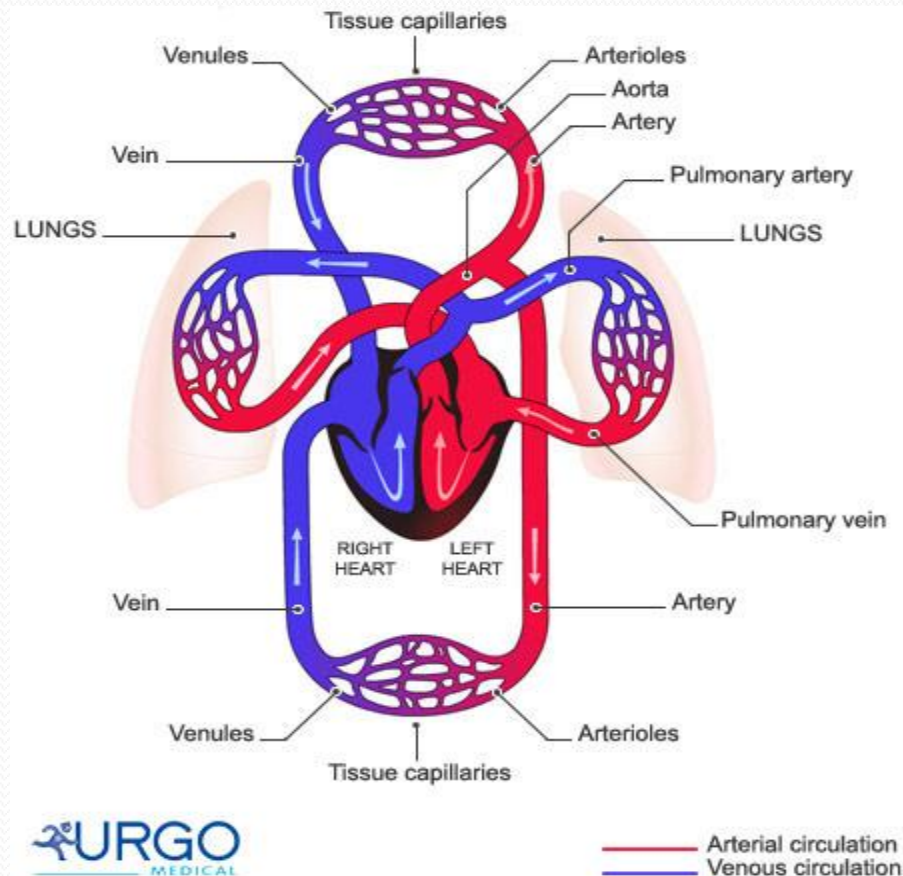







❖ Carnitine and its derivatives have recently been shown to protect cardiac metabolism and function in ischemic heart disease and other clinical conditions of myocardial ischemia.

Potential mechanisms of this effect include an increase in glucose metabolism, a reduction of toxic effects of long-chain acyl-CoA and acyl-carnitine in myocytes, an increase in coronary blood flow and anti-arrhythmic effect.

- 
- ❖ In addition, beneficial effects of carnitine supplementation have been demonstrated under a variety of clinical conditions such as during extracorporeal circulation, in carnitine-dependent cardiomyopathy as well as in patients with chronic circulatory failure and in cardiogenic shock.
  - ❖ However, further studies are required.

## Disturbances of myocardial function and carnitine metabolism

- ❖ Carnitine is released from ischemic myocardium, and its concentration in the coronary sinus is proportional to the concentration of lactate. These changes are reflected by a change in the ratio of free carnitine to carnitine esters in the heart. Anoxia caused by myocardial ischemia has been experimentally proven to be associated with the depletion of carnitine reserves and accumulation of toxic metabolites of fatty acid esterification, in consequence of restricted fatty-acids mitochondrial  $\beta$ -oxidation

- 
- ❖ That result is a decrease of ATP concentration in the heart. After only a few minutes of ischemia, free fatty acids, long-chain acyl-CoA esters and acyl-carnitine are all increased several times above the control level and after half an hour of ischemia, the free carnitine in the heart drops by half .

# Ischemic heart disease

❖ A decreased carnitine concentration in the heart was observed in patients who died of myocardial infarction. In patients with acute myocardial infarction, a four-fold increase was observed in free carnitine elimination and almost a two-fold increase in the elimination of short-chain carnitine esters by kidney.

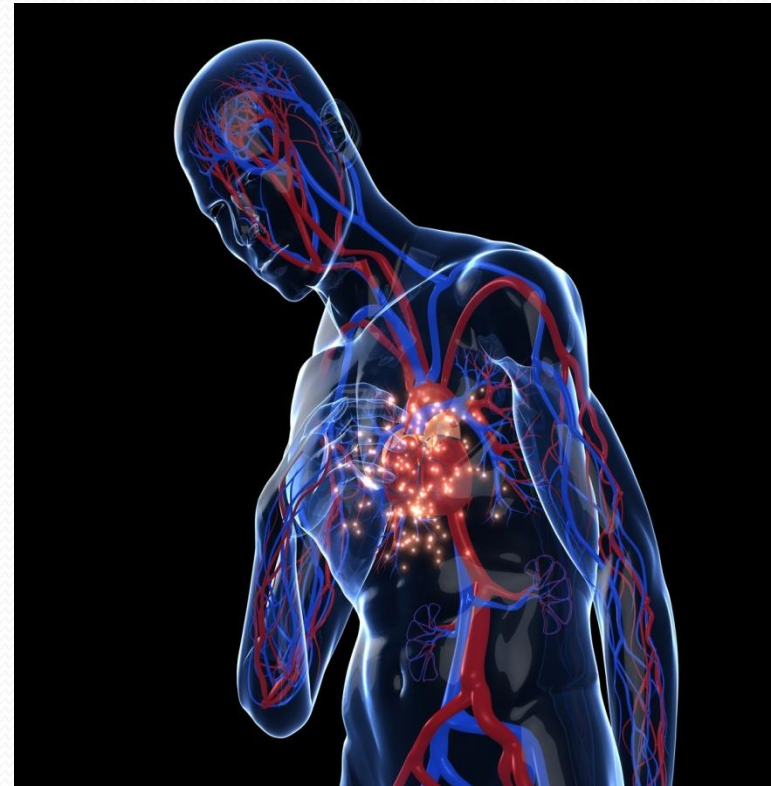



❖ Arsenian et al. demonstrated a decrease in mortality and incidence of circulatory failure in a group of patients with acute myocardial infarction, who were administered 3 g of carnitine along with solution of glucose, insulin, potassium and magnesium .

## Side effects:

Carnitine preparations administered orally can occasionally cause heart-burn and dyspepsia. Two patients treated with intravenous carnitine in doses of 6 g complained of blurred vision and one reported a headache.

Fairly high doses of carnitine administered orally may produce an unpleasant body odor that is similar to that of rotten fish.

There are no reports to date of serious side effects caused by L-carnitine and its derivatives.

## Conclusions:

The results reviewed in this article indicate that carnitine and propionyl-L-carnitine exert a positive metabolic and functional effect on myocardium in ischemic heart disease and in heart failure. The accumulated data resulting from experimental and clinical studies and general knowledge of myocardial metabolism in ischemia and reperfusion, allows us to expect encouraging clinical results especially in carnitine-deficient patients. However, some conflicting results do not permit definitive



# Carnitine and Thalassemia

- ❖ Recently some new therapeutic approaches including L-carnitine have been tried out as alternative as standard therapy for  $\beta$ -thalassemia major.
- ❖ L-carnitine has the potential to stabilize the erythrocyte membrane against oxidative stress.



- ❖ In a recent research 19 patients with homozygous  $\beta$  - thalassemia were enrolled, followed up at the Division of Pediatric Hematology/ Department of pediatrics/ Akdeniz University School of Medicine. All thalassemia major patients had received a regular erythrocyte transfusion, at 3 to 4 weeks intervals in order to maintain the pretransfusion hemoglobin level above 8.5 g/dl.
- ❖ The patients also received subcutaneously desferrioxamine 50 mg/kg/day for 5 days a week.
- ❖ All were treated with L-carnitine 100 mg/kg/day orally for 3 months.

- 
- ❖ 2 of the patients had a significant increase in their transfusion intervals from 4 to 12 for one and to 14 weeks for the other patient.
  - ❖ 1 patient had a mild increase from 4 to 6 weeks.
  - ❖ Other patient intervals did not change.
  - ❖ An increase in MCV values was noted in 8 patients.



THANK YOU.