

# **CLASSIFICATION OF TUNNELS**

Dr. Azealdeen Salih Al-Jawadi  
College of Petroleum and Mining  
Engineering

## **The shape and size of tunnels depend upon the following factors:**

1. The shape of the section is best suited to the condition.
2. The interior dimension of the section.

The shape of Section: The shape of the sectional profile should be such that the lining can resist the pressures exerted by the unsupported walls of the tunnel excavation. These pressures are both lateral and vertical in direction and vary with the character of the material penetrated i.e. cohesion and internal friction. The sectional profile of a tunnel should be designed to offer the greatest resistance at its highest points. The curve must therefore be sharper at the crown and may decrease towards the base.

## **The commonly adopted Sections are:**

1. Polycentric
2. Circular
3. Rectangular
4. Egg-shaped
5. Horseshoe type
6. Elliptical
7. Segmental

## Poly-centric Section:

This type of section suits the major conditions. The number of centers and length of the radii can be fixed by the Engineer, meeting the existing conditions. This sort of tunnel shape has a number of centers and provides a sufficient flat base for traffic movement.

## Advantages:

- It can be used for road and railway traffic.
- It can resist external and internal pressure for their arch shape.

## Disadvantages:

- The construction of these tunnels is difficult.
- The lining of this type of tunnel is difficult.

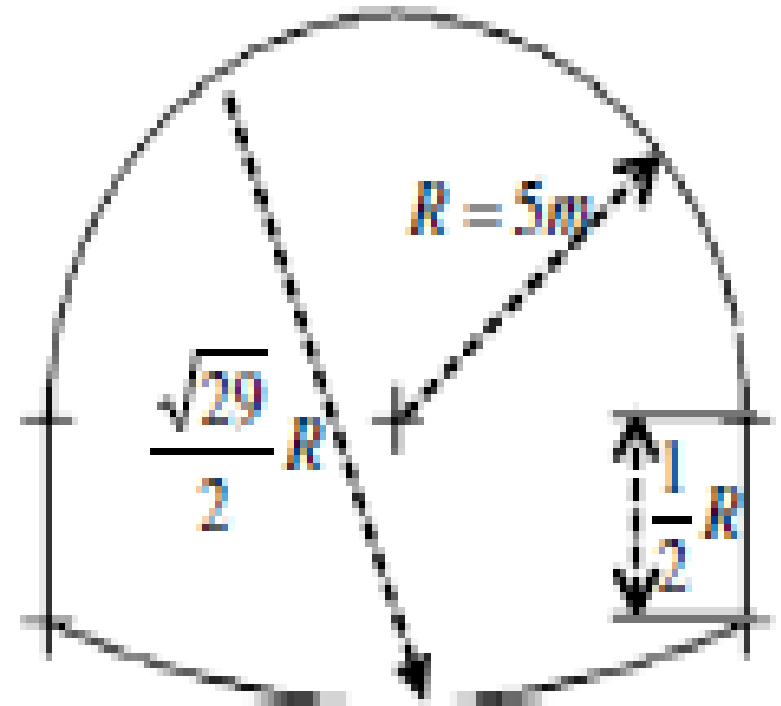

## **2. Circular Shaped Tunnels**

Circular tunnels are used to carry water under pressure. These are not appropriate for traffic tunnels because more filling is needed to make the base flat.

### **Advantages:**

- Best to resist the external or internal force.
- It provides the greatest cross-sectional area for the least perimeter.
- This type of tunnel is best for resisting internal or external pressures.
- It provides the greatest cross-sectional area for the last parameter.
- Best suited for carrying water as no necessity of filling.
- This type of tunnel is used for water and sewer conduits.
- Best suitable to construct in non-cohesive soils.

### **Disadvantages:**

- More filling is required to form a flat base for designing a road or railway track.
- In circular tunnels, lining work is very difficult.
- It requires a lot of filling for Railways and roadways.
- This shape is more difficult for the placement of concrete lining.

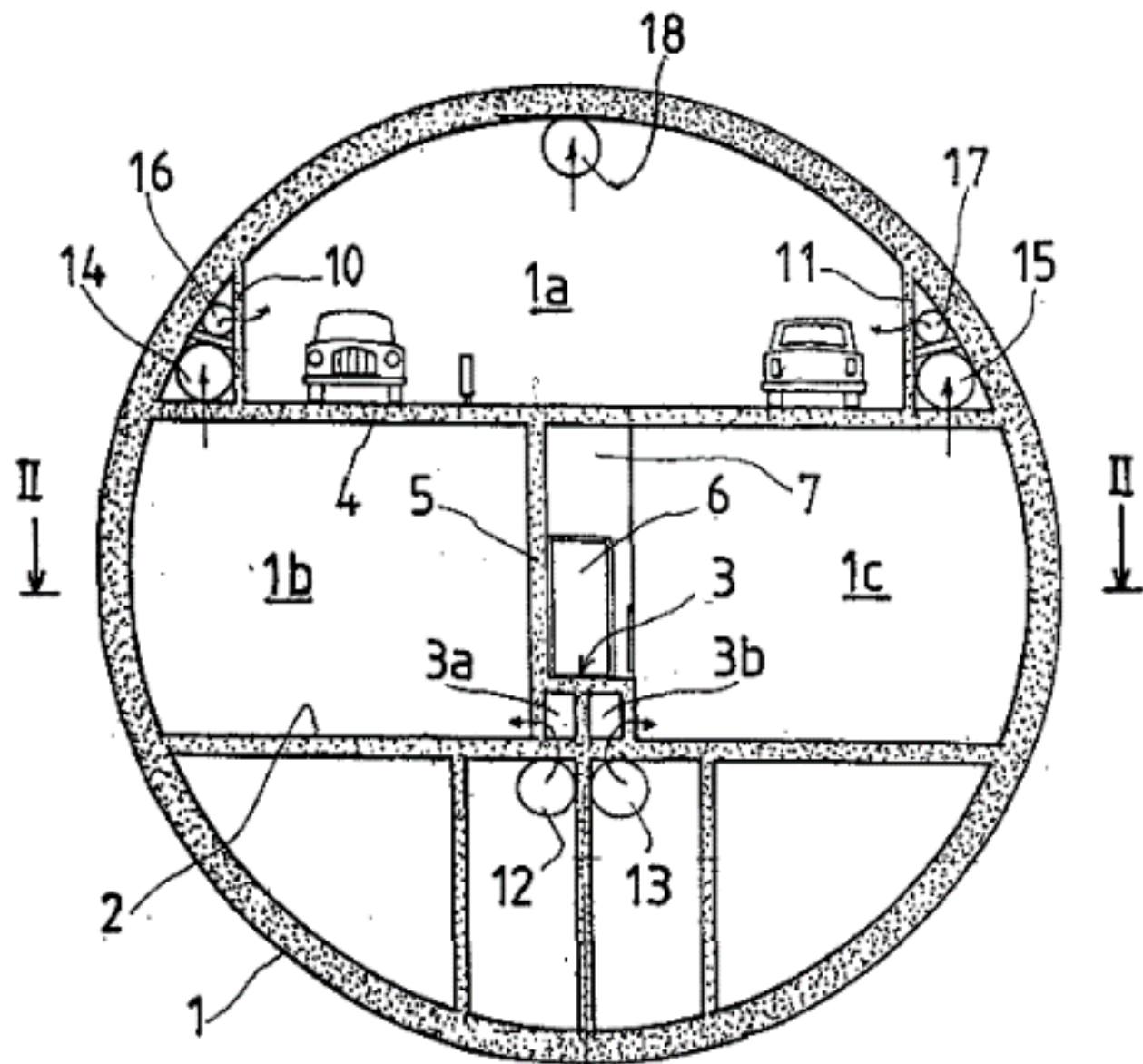

### **3. Rectangular Shaped Tunnels**

For pedestrian traffic, rectangular shapes of tunnels are appropriate. These tunnels are sometimes accepted if pre-constructed R.C.C caissons are used. These types of tunnels are not suitable to resist external pressure due to their rectangular shape and these are not in use these days.

### **4. Egg Shaped Tunnels**

This tunnel shape has a number of centers and radius lengths. These are suitable as sewer tunnels to carry sewage water.

#### **Advantages:**

- It is mostly adopted for carrying sewage water.
- Due to their small cross-section at the bottom, it can maintain the self-cleaning velocity of the flow of sewage in dry and rainy seasons.
- It can resist external and internal pressure due to their circular walls

#### **Disadvantages:**

- This type of tunnel is not suitable as traffic tunnels
- The construction process of these tunnels are very difficult

## **5. Horse Shoe Type Tunnels**

Horseshoe type tunnel shape is a combined shape of arches and circular tunnels. This type of tunnels shape is quite popular.

## **6. Elliptical Shaped Tunnels**

For carrying water, elliptical-shaped tunnels are appropriate. These are suitable for softer materials. For better resistance to external pressure, the major axis of these tunnels is maintained vertically.

## **7. Segmental or D shaped tunnels**

Segmental tunnels are suitable for traffic tunnels. It is a section with an arched roof and straight sides. These are generally used for subway or navigation tunnels.

### **Advantages:**

- It is the most suited in rock tunnels.
- It is suitable to resist external load due to its arch-shaped roof.
- It has a flat floor which is helpful during driving and moving any equipment.

Tunnels are generally classified on the basis of the purpose, types of material, and according to their position:

### **A. Classification Based on the Purpose**

Based on purpose tunnels are classified as:

#### **a. Traffic Tunnels**

Traffic tunnels are of the following types:

- Highway tunnels
- Railway tunnels
- Navigation Tunnels
- Pedestrian tunnels
- Subway tunnels





## **b. Conveyance Tunnels**

Conveyance tunnels are of the following types:

- Water supply tunnels
- Hydroelectric power tunnels
- Sewer tunnels
- Tunnels for intake and conduit of public utilities
- Transporting tunnels in industrial plant



## **B. Classification Based on Type of Material**

Based on the type of material through which they pass, tunnels are classified as:

- Tunnels in hard rock
- Tunnels in soft rock
- Tunnels in loose sand
- Tunnels in quicksand
- Open-cut tunnels
- Tunnels in the river bed



## **B. Classification Based on Type of Material**

Based on the type of material through which they pass, tunnels are classified as:

- Tunnels in hard rock
- Tunnels in soft rock
- Tunnels in loose sand
- Tunnels in quicksand
- Open-cut tunnels
- Tunnels in the river bed



## **B. Classification Based on Type of Material**

Based on the type of material through which they pass, tunnels are classified as:

- Tunnels in hard rock
- Tunnels in soft rock
- Tunnels in loose sand
- Tunnels in quicksand
- Open-cut tunnels
- Tunnels in the river bed



## C. Classification based on position or alignment

Based on position or alignment, tunnels are classified as:

- Spiral tunnels

The spiral tunnel is provided to increase the length of the tunnel to avoid steep slopes in narrow valleys. Tunnels are provided in a narrow valley in the form of loops in the interior of the mountain so as to increase the length of the tunnel to avoid steep slopes.



- Saddle and base tunnels

Saddle tunnels constructed in the valley along the natural slopes, these tunnels mainly used for transportation purposes. Or tunnels constructed in the valley along the natural slope till the slope does not exceed the ruling gradient.



- Off-spur tunnels

Off spur tunnels are constructed to shortcut minor obstacles is very high projections on the way, which cannot be followed with permitted curves.



- Slope tunnels

A tunnel constructed in steep hills for economic and safe operations of roads and railways none as sloping tunnels, this type of tunnel also used for transportation purpose mainly.





Thank  
you!