

Strength of Materials

Adil Akram Mahmood

Second stage

Chapter one

Stress

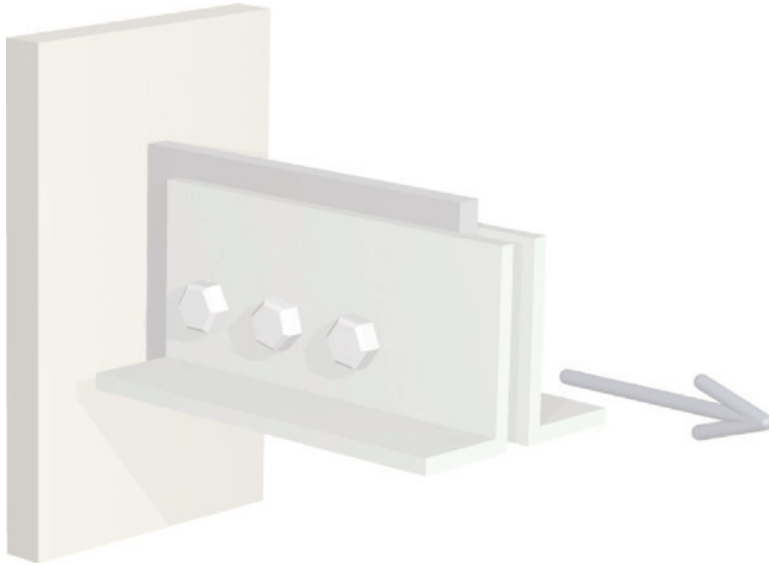

1.1 Introduction

The three fundamental areas of engineering mechanics are statics, dynamics, and mechanics of materials. Statics and dynamics are devoted primarily to the study of *external* forces and motions associated with particles and rigid bodies (i.e., idealized objects in which any change of size or shape due to forces can be neglected). Mechanics of materials is the study of the *internal* effects caused by external loads acting on real bodies that deform (meaning objects that can stretch, bend, or twist). Why are the internal effects in an object important? Engineers are called upon to design and produce a variety of objects and structures such as automobiles, airplanes, ships, pipelines, bridges, buildings, tunnels, retaining walls, motors, and machines. Regardless of the application, however, a safe and successful design must address the following three mechanical concerns:

- 1. Strength:** Is the object strong enough to withstand the loads that will be applied to it? Will it break or fracture? Will it continue to perform properly under repeated loadings?
- 2. Stiffness:** Will the object deflect or deform so much that it cannot perform its intended function?
- 3. Stability:** Will the object suddenly bend or buckle out of shape at some elevated load so that it can no longer continue to perform its function?

Addressing these concerns requires both an assessment of the intensity of internal forces and deformations acting within the body and an understanding of the mechanical characteristics of the material used to make the object.

Mechanics of materials is a basic subject in many engineering fields. The course focuses on several types of components: bars subjected to axial loads, shafts in torsion, beams in bending, and columns in compression. Numerous formulas and rules for design found in engineering codes and specifications are based on mechanics of materials fundamentals associated with these types of components. With a strong foundation in mechanics of materials concepts and problem-solving skills, the student is well equipped to continue into more advanced engineering design courses.

1.2 Normal Stress Under Axial Loading

In every subject area, there are certain fundamental concepts that assume paramount importance for a satisfactory comprehension of the subject matter. In mechanics of materials, such a concept is that of **stress**. In the simplest qualitative terms, *stress is the intensity of internal force*. Force is a vector quantity and as such has both magnitude and direction. Intensity implies an area over which the force is distributed. Therefore, stress can be defined as

$$\text{Stress} = \frac{\text{Force}}{\text{Area}} \quad (1.1)$$

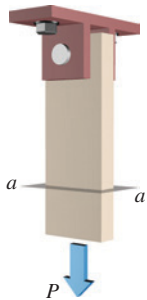

FIGURE 1.1a Bar with axial load P .

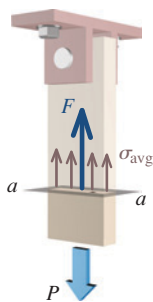

FIGURE 1.1b Average stress.

To introduce the concept of a **normal stress**, consider a rectangular bar subjected to an axial force (Figure 1.1a). An **axial force** is a load that is directed along the longitudinal axis of the member. Axial forces that tend to elongate a member are termed **tension forces**, and forces that tend to shorten a member are termed **compression forces**. The axial force P in Figure 1.1a is a tension force. To investigate internal effects, the bar is cut by a transverse plane, such as plane a – a of Figure 1.1a, to expose a free-body diagram of the bottom half of the bar (Figure 1.1b). Since this cutting plane is perpendicular to the longitudinal axis of the bar, the exposed surface is called a **cross section**.

The technique of cutting an object to expose the internal forces acting on a plane surface is often referred to as the **method of sections**. The cutting plane is called the **section plane**. To investigate internal effects, one might simply say something like “Cut a section through the bar” to imply the use of the method of sections technique. This technique will be used throughout the study of mechanics of materials to investigate the internal effects caused by external forces acting on a solid body.

Equilibrium of the lower portion of the bar is attained by a distribution of internal force that develops on the exposed cross section. This distribution of internal force has a resultant F that is normal to the exposed surface, is equal in magnitude to P , and has a line of action that is collinear with the line of action of P . The intensity of distributed internal force acting in the material is referred to as stress.

In this instance, the stress acts on a surface that is *perpendicular* to the direction of the internal force. A stress of this type is called a **normal stress**, and it is denoted by the Greek

letter σ (sigma). To determine the magnitude of the normal stress in the bar, the average intensity of internal force on the cross section can be computed as

$$\sigma_{\text{avg}} = \frac{F}{A} \quad (1.2)$$

where A is the cross-sectional area of the bar.

The **sign convention** for normal stresses is defined as follows:

- A positive sign indicates a *tension normal stress*, and
- a negative sign denotes a *compression normal stress*.

Consider now a small area ΔA on the exposed cross section of the bar, as shown in Figure 1.1c, and let ΔF represent the resultant of the internal forces transmitted in this small area. The average intensity of the internal force being transmitted in area ΔA is obtained by dividing ΔF by ΔA . If the internal forces transmitted across the section are assumed to be uniformly distributed, the area ΔA can be made smaller and smaller, and in the limit, it will approach a point on the exposed surface. The corresponding force ΔF also becomes smaller and smaller. The stress at the point on the cross section to which ΔA converges is defined as

$$\sigma = \lim_{\Delta A \rightarrow 0} \frac{\Delta F}{\Delta A} \quad (1.3)$$

If the distribution of stress is to be uniform, as in Equation (1.2), the resultant force must act through the centroid of the cross-sectional area. For long, slender, axially loaded members, such as those found in trusses and similar structures, it is generally assumed that the normal stress is uniformly distributed except near the points where external load is applied. Stress distributions in axially loaded members are not uniform near holes, grooves, fillets, and other features. These situations will be discussed in later sections on stress concentrations. *In this book, it is understood that axial forces are applied at the centroids of the cross sections unless specifically stated otherwise.*

Stress Units

Since the normal stress is computed by dividing the internal force by the cross-sectional area, stress has the dimensions of force per unit area. When U.S. Customary units are used, stress is commonly expressed in pounds per square inch (psi) or kips per square inch (ksi) where 1 kip = 1,000 lb. When the International System of Units, universally abbreviated SI (from the French *Le Système International d'Unités*), is used, stress is expressed in pascals (Pa) and computed as force in newtons (N) divided by area in square meters (m^2). For typical engineering applications, the pascal is a very small unit and, therefore, stress is more commonly expressed in megapascals (MPa) where 1 MPa = 1,000,000 Pa. A convenient alternative when calculating stress in MPa is to express force in newtons and area in square millimeters (mm^2). Therefore,

$$1 \text{ MPa} = 1,000,000 \text{ N/m}^2 = 1 \text{ N/mm}^2 \quad (1.4)$$

Significant Digits

In this book, final numerical answers are usually presented with three significant digits when a number begins with the digits 2 through 9, and with four significant digits when the

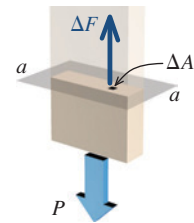
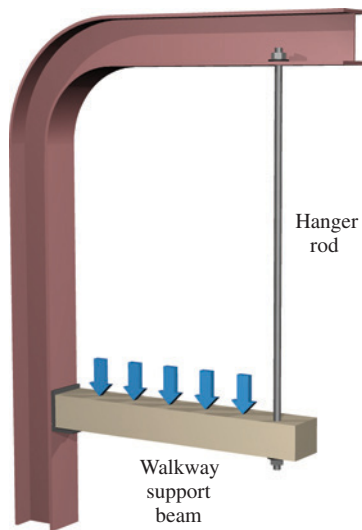

FIGURE 1.1c Stress at a point.

number begins with the digit 1. Intermediate values are generally recorded with additional digits to minimize the loss of numerical accuracy due to rounding.

In developing stress concepts through example problems and exercises, it is convenient to use the notion of a **rigid element**. Depending on how it is supported, a rigid element may move vertically or horizontally, or it may rotate about a support location. The rigid element is assumed to be infinitely strong.

EXAMPLE 1.1



A solid 0.5-in.-diameter steel hanger rod is used to hold up one end of a walkway support beam. The force carried by the rod is 5,000 lb. Determine the normal stress in the rod. (Disregard the weight of the rod.)

SOLUTION

A free-body diagram of the rod is shown. The solid rod has a circular cross section, and its area is computed as

$$A = \frac{\pi}{4} d^2 = \frac{\pi}{4} (0.5 \text{ in.})^2 = 0.19635 \text{ in.}^2$$

where d = rod diameter.

Since the force in the rod is 5,000 lb, the normal stress in the rod can be computed as

$$\sigma = \frac{F}{A} = \frac{5,000 \text{ lb}}{0.19635 \text{ in.}^2} = 25,464.73135 \text{ psi}$$

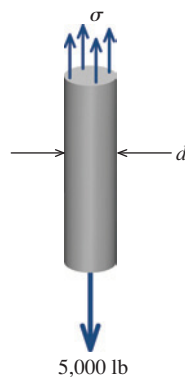

Free-body diagram of hanger rod.

Although this answer is numerically correct, it would not be proper to report a stress of 25,464.73135 psi as the final answer. A number with this many digits implies an accuracy that we

have no right to claim. In this instance, both the rod diameter and the force are given with only one significant digit of accuracy; however, the stress value we have computed here has 10 significant digits.

In engineering, it is customary to round the final answers to three significant digits (if the first digit is not 1) or four significant digits (if the first digit is 1). Using this guideline, the normal stress in the rod would be reported as

$$\sigma = 25,500 \text{ psi}$$

Ans.

In many instances, the illustrations in this book attempt to show objects in realistic three-dimensional perspective. Wherever possible, an effort has been made to show free-body diagrams within the actual context of the object or structure. In these illustrations, the free-body diagram is shown in full color, while other portions of the object or structure are faded out.

EXAMPLE 1.2

Rigid bar ABC is supported by a pin at A and axial member (1), which has a cross-sectional area of 540 mm^2 . The weight of rigid bar ABC can be neglected. (Note: $1 \text{ kN} = 1,000 \text{ N}$.)

- Determine the normal stress in member (1) if a load of $P = 8 \text{ kN}$ is applied at C .
- If the maximum normal stress in member (1) must be limited to 50 MPa , what is the maximum load magnitude P that may be applied to the rigid bar at C ?

Plan the Solution

(Part a)

Before the normal stress in member (1) can be computed, its axial force must be determined. To compute this force, consider a free-body diagram of rigid bar ABC and write a moment equilibrium equation about pin A .

SOLUTION

(Part a)

For rigid bar ABC , write the equilibrium equation for the sum of moments about pin A . Let $F_1 =$ internal force in member (1) and assume that F_1 is a tension force. Positive moments in the equilibrium equation are defined by the right-hand rule.

$$\begin{aligned}\Sigma M_A &= -(8 \text{ kN})(2.2 \text{ m}) + (1.6 \text{ m})F_1 = 0 \\ \therefore F_1 &= 11 \text{ kN}\end{aligned}$$

The normal stress in member (1) can be computed as

$$\sigma_1 = \frac{F_1}{A_1} = \frac{(11 \text{ kN})(1,000 \text{ N/kN})}{540 \text{ mm}^2} = 20.370 \text{ N/mm}^2 = 20.4 \text{ MPa} \quad \text{Ans.}$$

(Note the use of the conversion factor $1 \text{ MPa} = 1 \text{ N/mm}^2$.)

Plan the Solution

(Part b)

Using the stress given, compute the maximum force that member (1) may safely carry. Once this force is computed, use the moment equilibrium equation to determine the load P .

SOLUTION

(Part b)

Determine the maximum force allowed for member (1):

$$\sigma = \frac{F}{A}$$

$$\therefore F_1 = \sigma_1 A_1 = (50 \text{ MPa})(540 \text{ mm}^2) = (50 \text{ N/mm}^2)(540 \text{ mm}^2) = 27,000 \text{ N} = 27 \text{ kN}$$

Compute the maximum allowable load P from the moment equilibrium equation:

$$\begin{aligned}\Sigma M_A &= -(2.2 \text{ m})P + (1.6 \text{ m})(27 \text{ kN}) = 0 \\ \therefore P &= 19.64 \text{ kN} \quad \text{Ans.}\end{aligned}$$

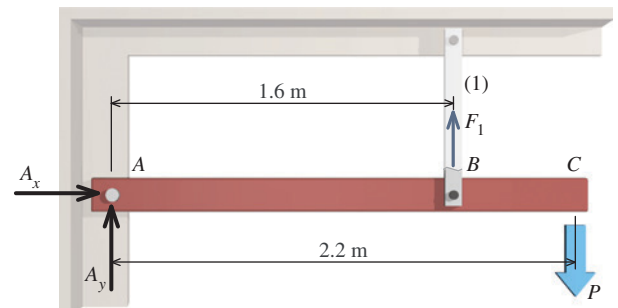
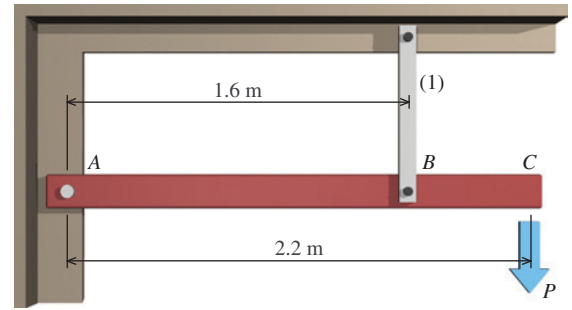

Free-body diagram of rigid bar ABC .

EXAMPLE 1.3

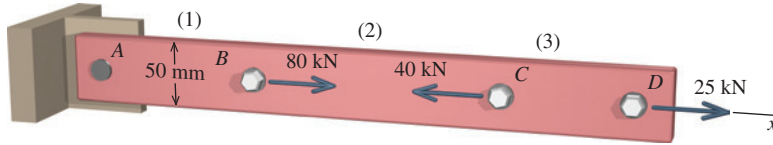

A 50-mm-wide steel bar has axial loads applied at points *B*, *C*, and *D*. If the normal stress magnitude in the bar must not exceed 60 MPa, determine the minimum thickness that can be used for the bar.

Plan the Solution

Draw free-body diagrams that expose the internal force in each of the three segments. Determine the magnitude and direction of the internal axial force in each segment required to satisfy equilibrium. Use the largest internal axial force magnitude and the allowable normal stress to compute the minimum cross-sectional area required for the bar. Divide the cross-sectional area by the 50-mm bar width to compute the minimum bar thickness.

SOLUTION

Begin by drawing a free-body diagram (FBD) that exposes the internal force in segment (3). Since the reaction force at *A* has not been calculated, it will be easier to cut through the bar in segment (3) and consider the portion of the bar starting at the cut surface and extending to the free end of the bar at *D*. An unknown internal axial force F_3 exists in segment (3), and it is helpful to establish a consistent convention for problems of this type.

Problem-Solving Tip: When cutting a FBD through an axial member, assume that the internal force is tension and draw the force arrow directed *away from the cut surface*. If the computed internal force value turns out to be a positive number, then the assumption of tension is confirmed. If the computed value turns out to be a negative number, then the internal force is actually compression.

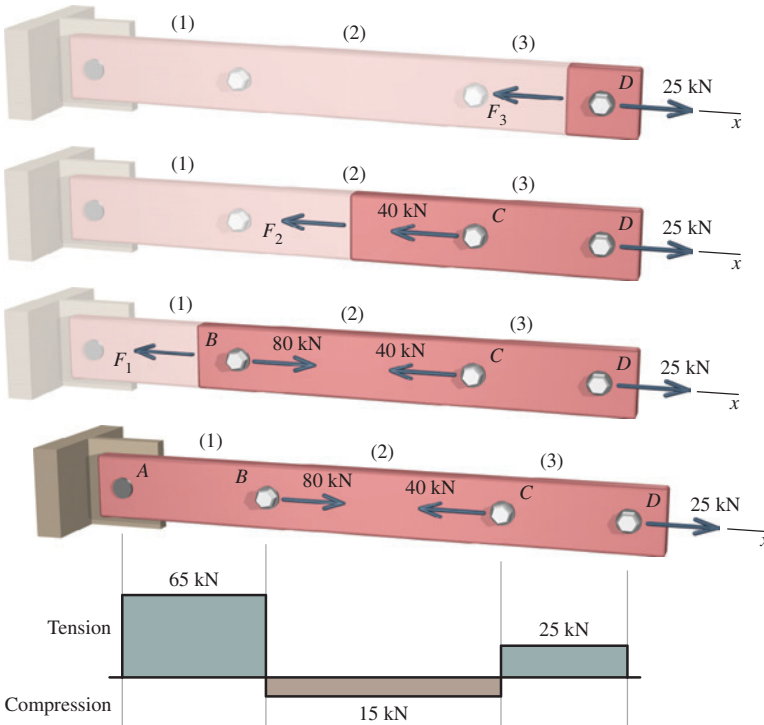

Axial-force diagram showing internal forces in each bar segment.

Based on a FBD cut through axial segment (3), the equilibrium equation is

$$\begin{aligned}\Sigma F_x &= -F_3 + 25 \text{ kN} = 0 \\ \therefore F_3 &= 25 \text{ kN} = 25 \text{ kN (T)}\end{aligned}$$

Repeat this procedure for a FBD exposing the internal force in segment (2),

$$\begin{aligned}\Sigma F_x &= -F_2 - 40 \text{ kN} + 25 \text{ kN} = 0 \\ \therefore F_2 &= -15 \text{ kN} = 15 \text{ kN (C)},\end{aligned}$$

and for a FBD exposing the internal force in segment (1),

$$\begin{aligned}\Sigma F_x &= -F_1 + 80 \text{ kN} - 40 \text{ kN} + 25 \text{ kN} = 0 \\ \therefore F_1 &= 65 \text{ kN (T)}\end{aligned}$$

It is always a good practice to construct a simple plot that graphically summarizes the internal axial forces along the bar. The axial-force diagram on the left shows internal tension forces above the axis and internal compression forces below the axis.

The required cross-sectional area will be computed on the basis of the largest internal force

magnitude (i.e., absolute value). The normal stress in the bar must be limited to 60 MPa. To facilitate the calculation, the conversion $1 \text{ MPa} = 1 \text{ N/mm}^2$ is used; therefore, $60 \text{ MPa} = 60 \text{ N/mm}^2$.

$$\sigma = \frac{F}{A} \quad \therefore A \geq \frac{F}{\sigma} = \frac{(65 \text{ kN})(1,000 \text{ N/kN})}{60 \text{ N/mm}^2} = 1,083.333 \text{ mm}^2$$

Since the flat steel bar is 50 mm wide, the minimum thickness that can be used for the bar is

$$t_{\min} \geq \frac{1,083,333 \text{ mm}^2}{50 \text{ mm}} = 21.667 \text{ mm} = 21.7 \text{ mm} \quad \text{Ans.}$$

In practice, the bar thickness would be rounded up to the next larger standard size.

Review

Recheck your calculations, paying particular attention to the units. Always show the units in your calculations because this is an easy and fast way to discover mistakes. Are the answers reasonable? If the bar thickness had been 0.0217 mm instead of 21.7 mm, would this have been a reasonable solution based on your common sense and intuition?



MecMovies Example M1.4

Two axial members are used to support a load P applied at joint B .

- Member (1) has a cross-sectional area of $A_1 = 3,080 \text{ mm}^2$ and an allowable normal stress of 180 MPa.
- Member (2) has a cross-sectional area of $A_2 = 4,650 \text{ mm}^2$ and an allowable normal stress of 75 MPa.

Determine the maximum load P that may be supported without exceeding either allowable normal stress.

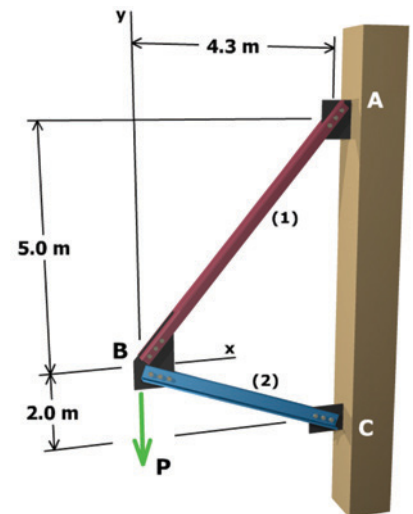

1.3 Direct Shear Stress

Loads applied to a structure or a machine are generally transmitted to individual members through connections that use rivets, bolts, pins, nails, or welds. In all of these connections, one of the most significant stresses induced is a *shear stress*. In the previous section, normal stress was defined as the intensity of internal force acting on a surface *perpendicular* to the direction of the internal force. Shear stress is also the intensity of internal force, but shear stress acts on a surface that is *parallel* to the internal force.

To investigate shear stress, consider a simple connection in which the force carried by an axial member is transmitted to a support by means of a solid circular pin (Figure 1.2a). The load is transmitted from the axial member to the support by **shear force** (i.e., a force that tends to cut) distributed on a transverse cross section of the pin. A free-body diagram

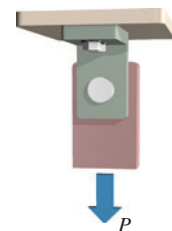

FIGURE 1.2a Single shear pin connection.

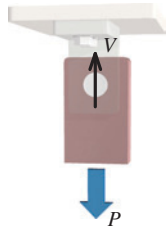

FIGURE 1.2b Free-body diagram showing shear force transmitted by pin.



MecMovies 1.7 and 1.8

present animated illustrations of single and double shear bolted connections.



MecMovies 1.9 presents an animated illustration of a shear key connection between a gear and a shaft.

of the axial member with the pin is shown in Figure 1.2*b*. In this diagram, a resultant shear force V has replaced the distribution of shear force on the transverse cross section of the pin. Equilibrium requires that the resultant shear force V equal the applied load P . Since only one cross section of the pin transmits load between the axial member and the support, the pin is said to be in **single shear**.

From the definition of stress given by Equation (1.1), an average shear stress on the transverse cross section of the pin can be computed as

$$\tau_{\text{avg}} = \frac{V}{A_V} \quad (1.5)$$

where A_V = area transmitting shear stress. The Greek letter τ (tau) is commonly used to denote shear stress. A sign convention for shear stress will be presented in a later section of the book.

The stress at a point on the transverse cross section of the pin can be obtained by using the same type of limit process that was used to obtain Equation (1.3) for the normal stress at a point. Thus,

$$\tau = \lim_{\Delta A_V \rightarrow 0} \frac{\Delta V}{\Delta A_V} \quad (1.6)$$

It will be shown later in this text that the shear stresses cannot be uniformly distributed over the transverse cross section of a pin or bolt and that the *maximum shear stress* on the transverse cross section may be much larger than the average shear stress obtained by using Equation (1.5). The design of simple connections, however, is usually based on average stress considerations, and this procedure will be followed in this book.

The key to determining shear stress in connections is to visualize the failure surface or surfaces that will be created if the connectors (i.e., pins, bolts, nails, or welds) actually break (i.e., fracture). The shear area A_V that transmits shear force is the area exposed when the connector fractures. Two common types of shear failure surfaces for pinned or bolted connections are shown in Figures 1.3 and 1.4. Laboratory specimens that have failed on a single shear



Jeffery S. Thomas

FIGURE 1.3 Single shear failure in pin specimens.



Jeffery S. Thomas

FIGURE 1.4 Double shear failure in a pin specimen.

plane are shown in Figure 1.3. Similarly, a pin that has failed on two parallel shear planes is shown in Figure 1.4.

EXAMPLE 1.4

Chain members (1) and (2) are connected by a shackle and pin. If the axial force in the chains is $P = 28 \text{ kN}$ and the allowable shear stress in the pin is $\tau_{\text{allow}} = 90 \text{ MPa}$, determine the minimum acceptable diameter d for the pin.

Plan the Solution

To solve the problem, first visualize the surfaces that would be revealed if the pin fractured due to the applied load P . Shear stress will be developed in the pin on these surfaces, which will occur at the two interfaces (i.e., common boundaries) between the pin and the shackle. The shear area needed to resist the shear force acting on each of these surfaces must be found, and from this area the minimum pin diameter can be calculated.

SOLUTION

Draw a free-body diagram (FBD) of the pin, which connects chain (2) to the shackle. Two shear forces V will resist the applied load of $P = 28 \text{ kN}$. The shear force V acting on each surface must equal one-half of the applied load P ; therefore, $V = 14 \text{ kN}$.

Next, the area of each surface is simply the cross-sectional area of the pin. The average shear stress acting on each of the pin failure surfaces is, therefore, the shear force V divided by the cross-sectional area of the pin. Since the average shear stress must be limited to 90 MPa , the minimum cross-sectional area required to satisfy the allowable shear stress requirement can be computed as

$$\tau = \frac{V}{A_{\text{pin}}} \quad \therefore A_{\text{pin}} \geq \frac{V}{\tau_{\text{allow}}} = \frac{(14 \text{ kN})(1,000 \text{ N/kN})}{90 \text{ N/mm}^2} = 155.556 \text{ mm}^2$$

The minimum pin diameter required for use in the shackle can be determined from the required cross-sectional area:

$$A_{\text{pin}} \geq \frac{\pi}{4} d_{\text{pin}}^2 = 155.556 \text{ mm}^2 \quad \therefore d_{\text{pin}} \geq 14.07 \text{ mm} \quad \text{say, } d_{\text{pin}} = 15 \text{ mm} \quad \text{Ans.}$$

In this connection, two cross sections of the pin are subjected to shear forces V ; consequently, the pin is said to be in **double shear**.

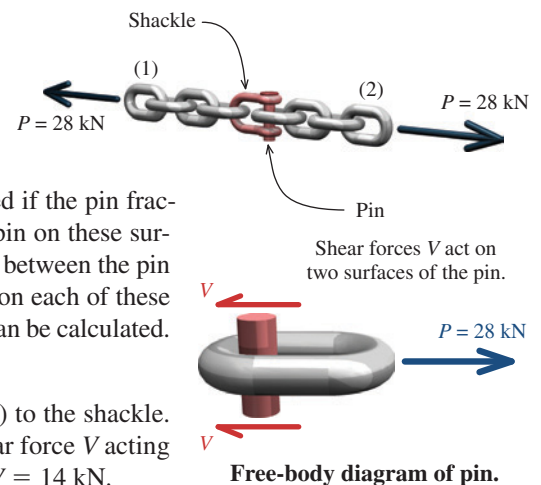



MecMovies Example M1.5

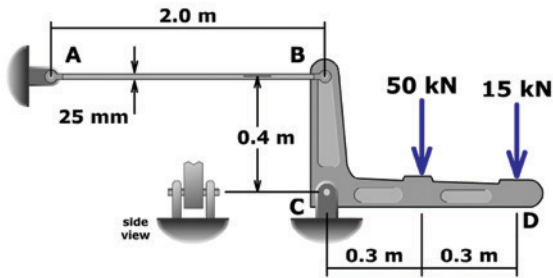

A pin at C and a round aluminum rod at B support the rigid bar BCD . If the allowable pin shear stress is 50 MPa , what is the minimum diameter required for the pin at C ?

EXAMPLE 1.5

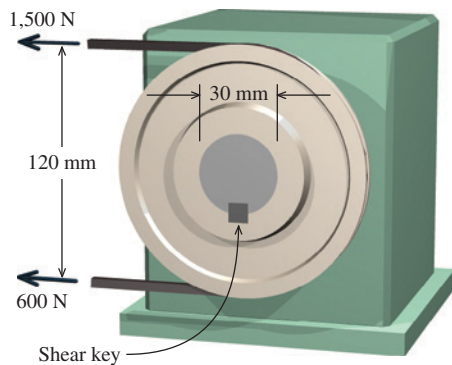

A belt pulley used to drive a device is attached to a 30-mm -diameter shaft with a square shear key. The belt tensions are $1,500 \text{ N}$ and 600 N , as shown. The shear key dimensions are 6 mm by 6 mm by 25 mm long. Determine the shear stress produced in the shear key.

Plan the Solution

A shear key is a common component used to connect pulleys, chain sprockets, and gears to solid circular shafts. A rectangular slot is cut in the shaft, and a matching notch of the same width is cut in the pulley. After the slot and the notch are aligned, a square metal piece is inserted in the opening. This metal piece is called a shear key; it forces the shaft and the pulley to rotate together.

Before beginning the calculations, try to visualize the failure surface in the shear key. Since the belt tensions are unequal, a moment is created about the center of the shaft that causes the shaft and pulley to rotate. This type of moment is called a **torque**. If the torque T created by the unequal belt tensions is too large, the shear key will break at the interface between the shaft and the pulley, allowing the pulley to spin freely on the shaft. This failure surface is the plane at which shear stress is created in the shear key.

From the belt tensions and the pulley diameter, determine the torque T exerted on the shaft by the pulley. From a free-body diagram (FBD) of the pulley, determine the force that must be supplied by the shear key to satisfy equilibrium. Once the force in the shear key is known, the shear stress in the key can be computed by using the shear key dimensions.

SOLUTION

Consider a FBD of the pulley. This FBD includes the belt tensions, but it specifically excludes the shaft. The FBD cuts through the shear key at the interface between the pulley and the shaft. We will assume that there could be internal force acting on the exposed surface of the shear key. This force will be denoted as shear force V . The distance from V to the center O of the shaft is equal to the radius of the shaft. Since the shaft diameter is 30 mm , the distance from O to shear force V is 15 mm . The magnitude of shear force V can be found from a moment equilibrium equation about

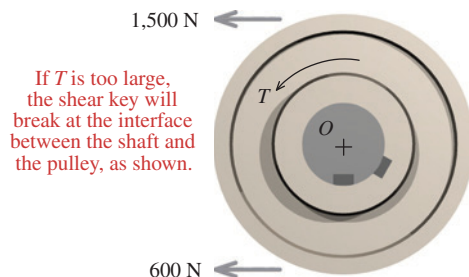

Visualize failure surface in shear key.

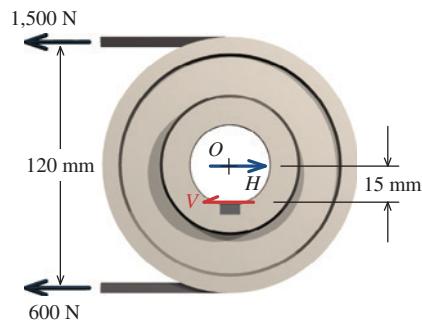

Free-body diagram of pulley.

point O , which is the center of rotation for both the pulley and the shaft. In this equation, positive moments are defined by the right-hand rule:

$$\Sigma M_O = (1,500 \text{ N})(60 \text{ mm}) - (600 \text{ N})(60 \text{ mm}) - (15 \text{ mm})V = 0$$

$$\therefore V = 3,600 \text{ N}$$

For the pulley to be in equilibrium, a shear force of $V = 3,600 \text{ N}$ must be supplied by the shear key.

An enlarged view of the shear key is shown on the right. The torque created by the belt tensions exerts a force of 3,600 N on the shear key. For equilibrium, a force equal in magnitude, but opposite in direction, must be exerted on the key by the shaft. This pair of forces tends to cut the key, producing a shear stress. The shear stress acts on the plane highlighted in red.

An internal force of $V = 3,600 \text{ N}$ must exist on an internal plane of the shear key if the pulley is to be in equilibrium. The area of this plane surface is the product of the shear key width and length:

$$A_V = (6 \text{ mm})(25 \text{ mm}) = 150 \text{ mm}^2$$

The shear stress produced in the shear key can now be computed:

$$\tau = \frac{V}{A_V} = \frac{3,600 \text{ N}}{150 \text{ mm}^2} = 24.0 \text{ N/mm}^2 = 24.0 \text{ MPa}$$

Ans.

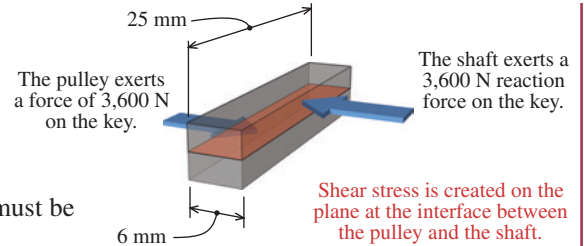

Enlarged view of shear key.



MecMovies Example M1.6

A torque of $T = 10 \text{ kN}\cdot\text{m}$ is transmitted between two flanged shafts by means of four 22-mm-diameter bolts. Determine the average shear stress in each bolt if the diameter of the bolt circle is 250 mm. (Disregard friction between the flanges.)

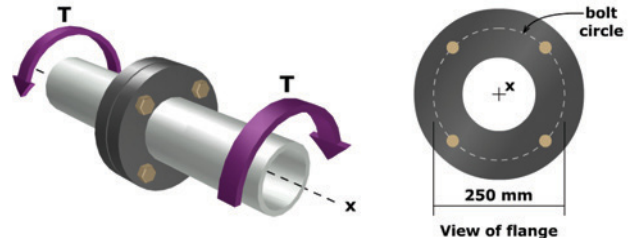

Another common type of shear loading is termed **punching shear**. Examples of this type of loading include the action of a punch in forming rivet holes in a metal plate, the tendency of building columns to punch through footings, and the tendency of a tensile axial load on a bolt to pull the shank of the bolt through the head. Under a punching shear load, the significant stress is the average shear stress on the surface described by the *perimeter* of the punching member and the *thickness* of the punched member. Punching shear is illustrated by the three composite wood specimens shown in Figure 1.5. The central hole in each specimen is a pilot hole used to guide the punch. The specimen on the left shows the surface initiated at the outset of the shear failure. The center specimen reveals the failure surface after the punch is driven partially through the block. The specimen on the right shows the block after the punch has been driven completely through the block.



MecMovies 1.10 presents an animated illustration of punching shear.



Jeffery S. Thomas

FIGURE 1.5 Punching shear failure in composite wood block specimens.

EXAMPLE 1.6

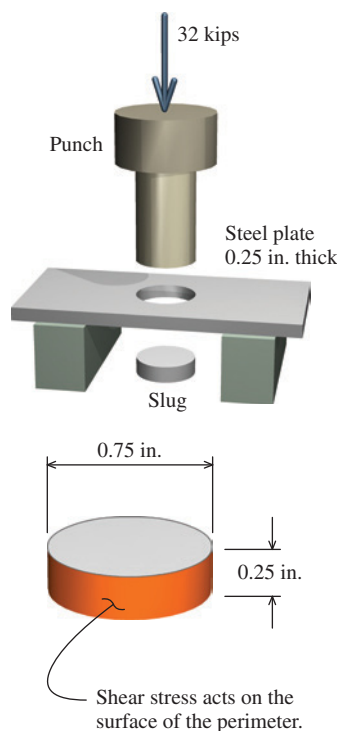

A punch for making holes in steel plates is shown. A downward punching force of 32 kips is required to punch a 0.75-in.-diameter hole in a steel plate that is 0.25 in. thick. Determine the average shear stress in the steel plate at the instant when the circular slug is torn away from the steel plate.

Plan the Solution

Visualize the surface that is revealed when the slug is removed from the plate. Compute the shear stress from the applied punching force and the area of the exposed surface.

SOLUTION

The portion of the steel plate removed to create the hole is called a slug. The area subjected to shear stress occurs around the perimeter of the slug. Use the slug diameter d and the plate thickness t to compute the shear area A_V :

$$A_V = \pi dt = \pi(0.75 \text{ in.})(0.25 \text{ in.}) = 0.58905 \text{ in.}^2$$

The average shear stress τ is computed from the punching force $P = 32$ kips and the shear area:

$$\tau = \frac{P}{A_V} = \frac{32 \text{ kips}}{0.58905 \text{ in.}^2} = 54.3 \text{ ksi}$$

Ans.

1.4 Bearing Stress

A third type of stress, **bearing stress**, is actually a special category of normal stress. Bearing stresses are compressive normal stresses that occur on the surface of contact *between two separate interacting members*. This type of normal stress is defined in the same manner as normal and shear stresses (i.e., force per unit area); therefore, the average bearing stress σ_b is expressed as

$$\sigma_b = \frac{F}{A_b} \quad (1.7)$$

where A_b = area of contact between the two components.

EXAMPLE 1.7

A steel pipe column (6.5-in. outside diameter; 0.25-in. wall thickness) supports a load of 11 kips. The steel pipe rests on a square steel base plate, which in turn rests on a concrete slab.

- Determine the bearing stress between the steel pipe and the steel plate.
- If the bearing stress of the steel plate on the concrete slab must be limited to 90 psi, what is the minimum allowable plate dimension a ?

Plan the Solution

To compute bearing stress, the area of contact between two objects must be determined.

SOLUTION

- The cross-sectional area of the pipe is required to compute the compressive bearing stress between the column post and the base plate. The cross-sectional area of a pipe is given by

$$A_{\text{pipe}} = \frac{\pi}{4}(D^2 - d^2)$$

where D = outside diameter and d = inside diameter. The inside diameter d is related to the outside diameter D by

$$d = D - 2t$$

where t = wall thickness. Therefore, with $D = 6.5$ in. and $t = 0.25$ in., the area of the pipe is

$$A_{\text{pipe}} = \frac{\pi}{4}(D^2 - d^2) = \frac{\pi}{4}[(6.5 \text{ in.})^2 - (6.0 \text{ in.})^2] = 4.9087 \text{ in.}^2$$

The bearing stress between the pipe and the base plate is

$$\sigma_b = \frac{F}{A_b} = \frac{11 \text{ kips}}{4.9087 \text{ in.}^2} = 2.24 \text{ ksi}$$

- The minimum area required for the steel plate in order to limit the bearing stress to 90 psi is

$$\sigma_b = \frac{F}{A_b} \quad \therefore A_b = \frac{F}{\sigma_b} = \frac{(11 \text{ kips})(1,000 \text{ lb/kip})}{90 \text{ psi}} = 122.222 \text{ in.}^2$$

Since the steel plate is square, its area of contact with the concrete slab is

$$A_b = a \times a = 122.222 \text{ in.}^2 \quad \therefore a = \sqrt{122.222 \text{ in.}^2} = 11.06 \text{ in.} \quad \text{say, 12 in.} \quad \mathbf{Ans.}$$

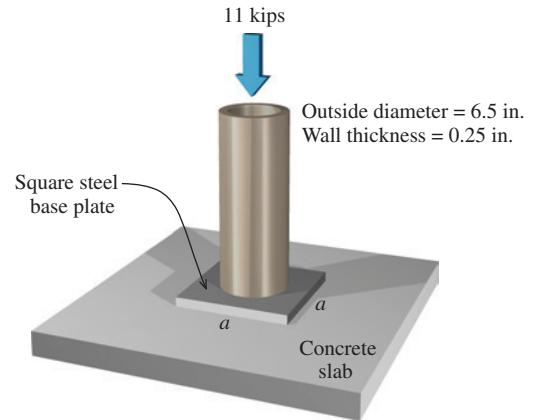

Bearing stresses also develop on the contact surface between a plate and the body of a bolt or a pin. A bearing failure at a bolted connection in a thin steel component is shown in Figure 1.6. A tension load was applied upward to the steel component, and a bearing failure occurred below the bolt hole.

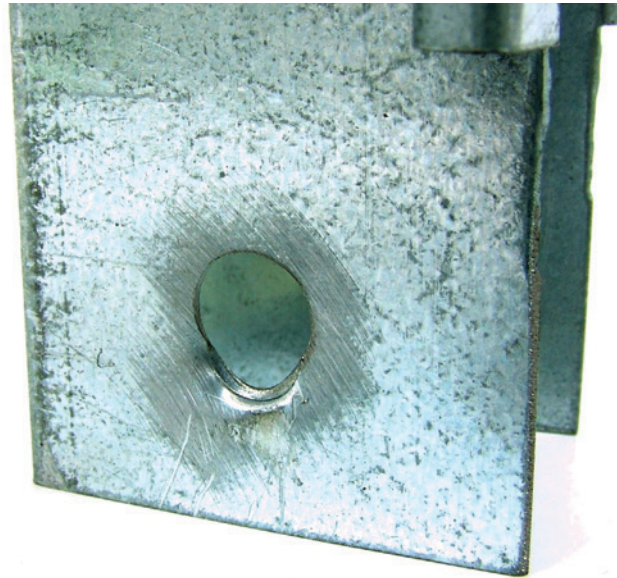

Jeffery S. Thomas

FIGURE 1.6 Bearing stress failure at a bolted connection.

The distribution of these stresses on a semicircular contact surface is quite complicated, and an average bearing stress is often used for design purposes. This average bearing stress σ_b is computed by dividing the transmitted force by the **projected area** of contact between a plate and the bolt or pin, instead of the actual contact area. This approach is illustrated in the following example.

EXAMPLE 1.8

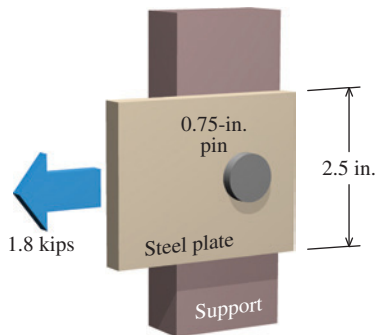

A 2.5-in.-wide by 0.125-in.-thick steel plate is connected to a support with a 0.75-in.-diameter pin. The steel plate carries an axial load of 1.8 kips. Determine the bearing stress in the steel plate.

Plan the Solution

Bearing stresses will develop on the surface where the steel plate contacts the pin, which is the right side of the hole in the illustration. To determine the average bearing stress, the projected area of contact between the plate and the pin must be calculated.

SOLUTION

The 1.8-kip load pulls the steel plate to the left, which brings the right side of the hole into contact with the pin. Bearing stresses will occur on the right side of the hole (in the steel plate) and on the right half of the pin.

Since the actual distribution of bearing stress on a semicircular surface is complicated, an average bearing stress is typically used for design purposes. Instead of using the actual contact area, the projected area of contact is used in the calculation.

The figure to the left shows an enlarged view of the projected contact area between the steel plate and the pin. An average bearing stress σ_b is exerted on the steel plate by the pin. Not shown is the equal magnitude bearing stress exerted on the pin by the steel plate.

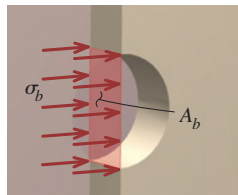

Enlarged view of projected contact area.

The projected area A_b is equal to the product of the pin (or bolt) diameter d and the plate thickness t . For the pinned connection shown, the projected area A_b between the 0.125-in.-thick steel plate and the 0.75-in.-diameter pin is calculated as

$$A_b = dt = (0.75 \text{ in.})(0.125 \text{ in.}) = 0.09375 \text{ in.}^2$$

The average bearing stress between the plate and the pin is

$$\sigma_b = \frac{F}{A_b} = \frac{1.8 \text{ kips}}{0.09375 \text{ in.}^2} = 19.20 \text{ ksi}$$

Ans.



MecMovies Example M1.1

A 60-mm-wide by 8-mm-thick steel plate is connected to a gusset plate by a 20-mm-diameter pin. If a load of $P = 70 \text{ kN}$ is applied, determine the normal, shear, and bearing stresses in this connection.

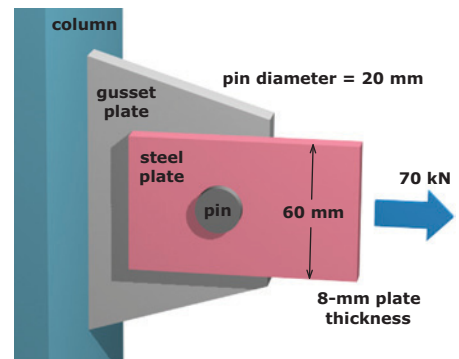

MecMovies Exercises

M1.1 For the pin connection shown, determine the normal stress acting on the gross area, the normal stress acting on the net area, the shear stress in the pin, and the bearing stress in the steel plate at the pin.

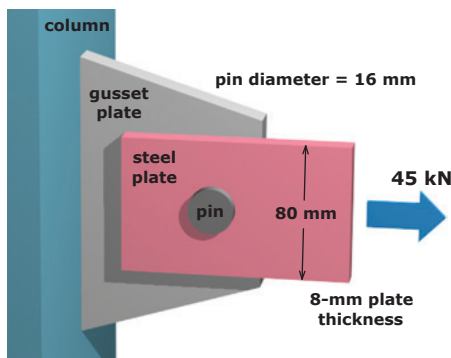

FIGURE M1.1

M1.2 Use normal stress concepts for four introductory problems.

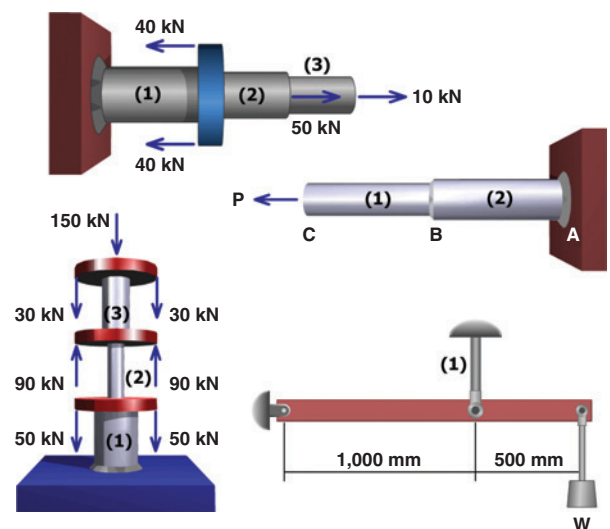

FIGURE M1.2

M1.3 Use shear stress concepts for four introductory problems.

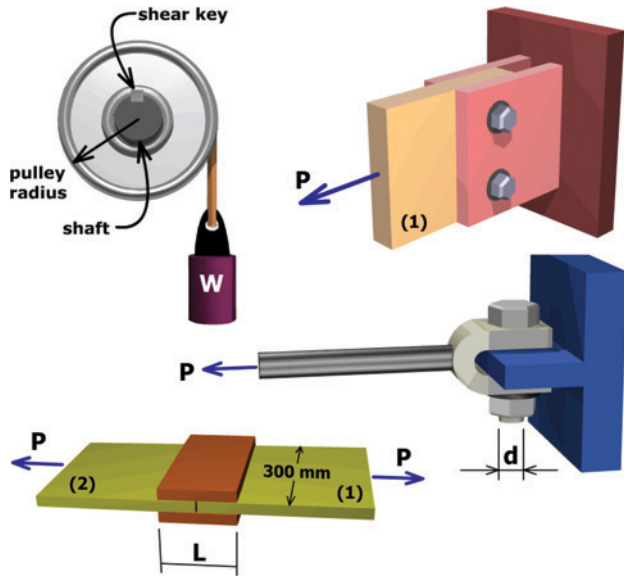

FIGURE M1.3

M1.4 Given the areas and allowable normal stresses for members (1) and (2), determine the maximum load P that may be supported by the structure without exceeding either allowable stress.

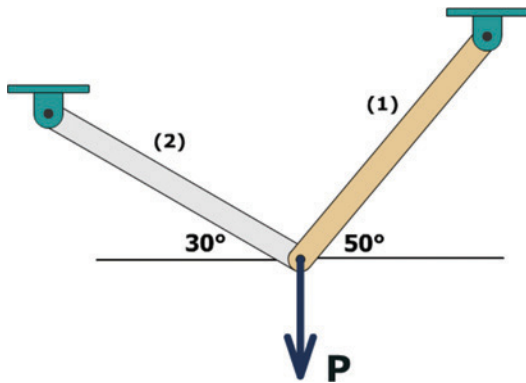

FIGURE M1.4

M1.5 For the pin at C , determine the resultant force, the shear stress, or the minimum required pin diameter for six configuration variations.

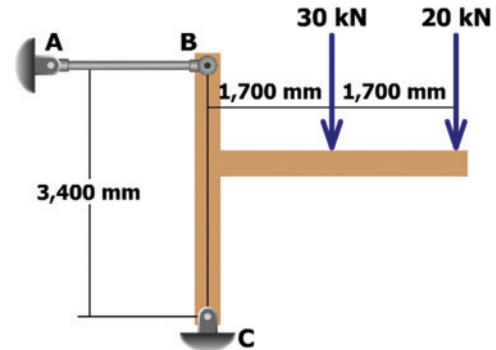

FIGURE M1.5

M1.6 A torque T is transmitted between two flanged shafts by means of six bolts. If the shear stress in the bolts must be limited to a specified value, determine the minimum bolt diameter required for the connection.

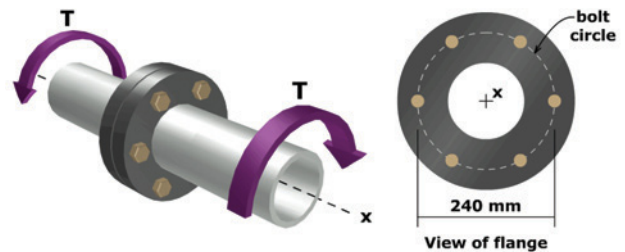

FIGURE M1.6

PROBLEMS

P1.1 A stainless steel tube with an outside diameter of 60 mm and a wall thickness of 5 mm is used as a compression member. If the axial normal stress in the member must be limited to 200 MPa, determine the maximum load P that the member can support.

P1.2 A 2024-T4 aluminum tube with an outside diameter of 2.50 in. will be used to support a 27-kip load. If the axial normal stress in the member must be limited to 18 ksi, determine the wall thickness required for the tube.

P1.3 Two solid cylindrical rods (1) and (2) are joined together at flange B and loaded as shown in Figure P1.3/4. If the normal stress in each rod must be limited to 40 ksi, determine the minimum diameter required for each rod.

P1.4 Two solid cylindrical rods (1) and (2) are joined together at flange B and loaded, as shown in Figure P1.3/4. The diameter of rod (1) is 1.75 in. and the diameter of rod (2) is 2.50 in. Determine the normal stresses in rods (1) and (2).

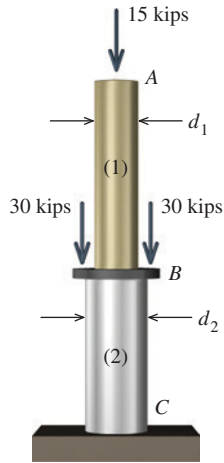

FIGURE P1.3/4

P1.5 Axial loads are applied with rigid bearing plates to the solid cylindrical rods shown in Figure P1.5/6. The diameter of aluminum rod (1) is 2.00 in., the diameter of brass rod (2) is 1.50 in., and the diameter of steel rod (3) is 3.00 in. Determine the axial normal stress in each of the three rods.

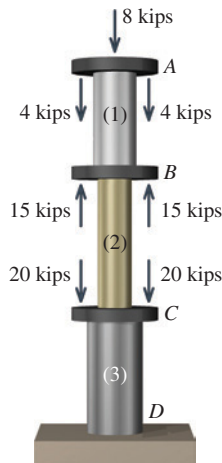

FIGURE P1.5/6

P1.6 Axial loads are applied with rigid bearing plates to the solid cylindrical rods shown in Figure P1.5/6. The normal stress in aluminum rod (1) must be limited to 18 ksi, the normal stress in brass rod (2) must be limited to 25 ksi, and the normal stress in steel rod (3) must be limited to 15 ksi. Determine the minimum diameter required for each of the three rods.

P1.7 Two solid cylindrical rods support a load of $P = 50$ kN, as shown in Figure P1.7/8. If the normal stress in each rod must be limited to 130 MPa, determine the minimum diameter required for each rod.

P1.8 Two solid cylindrical rods support a load of $P = 27$ kN, as shown in Figure P1.7/8. Rod (1) has a diameter of 16 mm, and the diameter of rod (2) is 12 mm. Determine the axial normal stress in each rod.

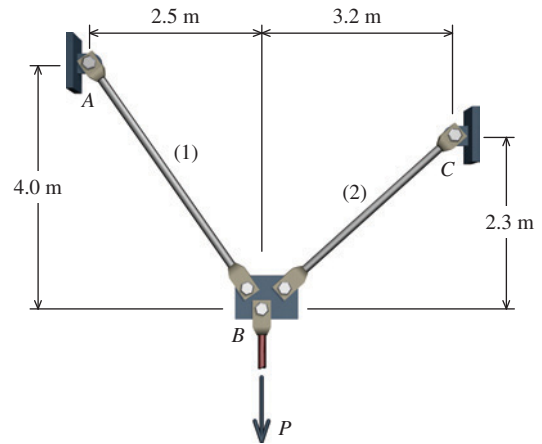

FIGURE P1.7/8

P1.9 A simple pin-connected truss is loaded and supported as shown in Figure P1.9. All members of the truss are aluminum pipes that have an outside diameter of 4.00 in. and a wall thickness of 0.226 in. Determine the normal stress in each truss member.

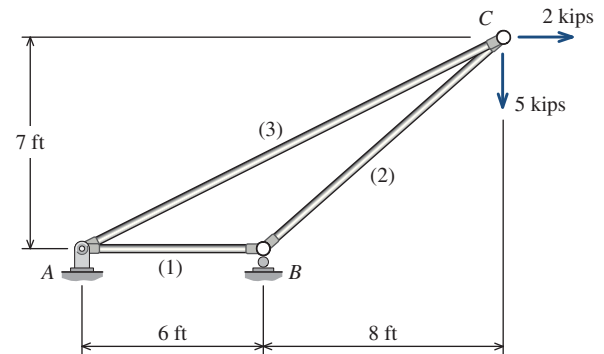

FIGURE P1.9

P1.10 A simple pin-connected truss is loaded and supported as shown in Figure P1.10. All members of the truss are aluminum pipes that have an outside diameter of 60 mm and a wall thickness of 4 mm. Determine the normal stress in each truss member.

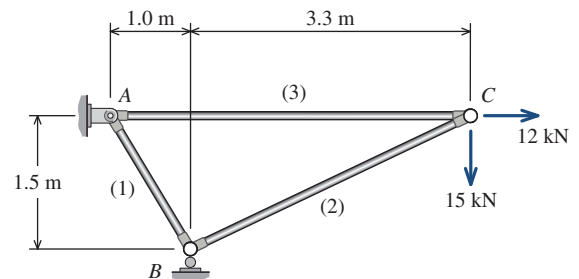

FIGURE P1.10

P1.11 A simple pin-connected truss is loaded and supported as shown in Figure P1.11. All members of the truss are aluminum pipes that have an outside diameter of 42 mm and a wall thickness of 3.5 mm. Determine the normal stress in each truss member.

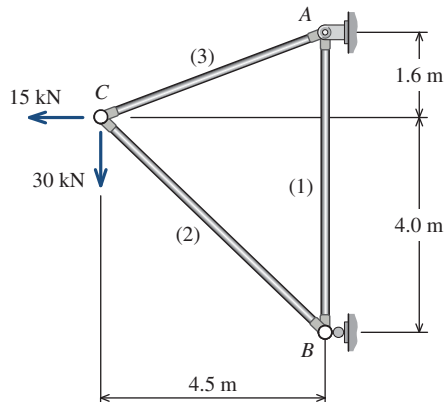

FIGURE P1.11

P1.12 The rigid beam BC shown in Figure P1.12 is supported by rods (1) and (2) that have cross-sectional areas of 175 mm^2 and 300 mm^2 , respectively. For a uniformly distributed load of $w = 15 \text{ kN/m}$, determine the normal stress in each rod. Assume $L = 3 \text{ m}$ and $a = 1.8 \text{ m}$.

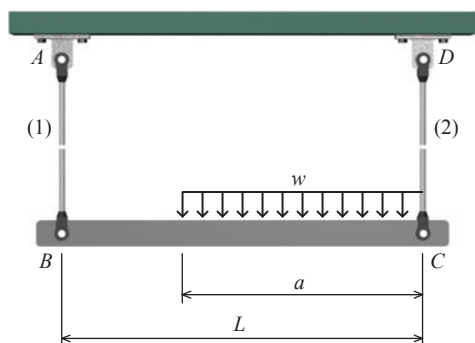

FIGURE P1.12

P1.13 Bar (1) in Figure P1.13 has a cross-sectional area of 0.75 in.^2 . If the stress in bar (1) must be limited to 30 ksi, determine the maximum load P that may be supported by the structure.

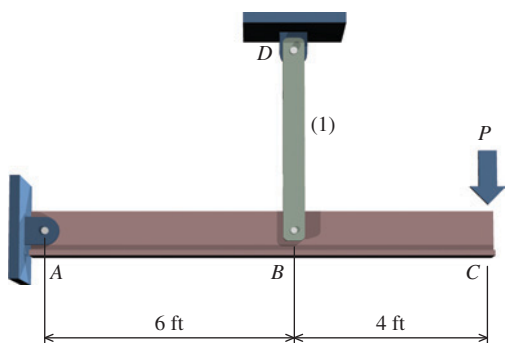

FIGURE P1.13

P1.14 The rectangular bar shown in Figure P1.14 is subjected to a uniformly distributed axial loading of $w = 13 \text{ kN/m}$ and a concentrated force of $P = 9 \text{ kN}$ at B . Determine the magnitude of the maximum normal stress in the bar and its location x . Assume $a = 0.5 \text{ m}$, $b = 0.7 \text{ m}$, $c = 15 \text{ mm}$, and $d = 40 \text{ mm}$.

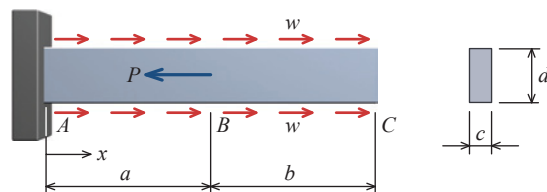

FIGURE P1.14

P1.15 The solid 1.25-in.-diameter rod shown in Figure P1.15 is subjected to a uniform axial distributed loading along its length of $w = 750 \text{ lb/ft}$. Two concentrated loads also act on the rod: $P = 2,000 \text{ lb}$ and $Q = 1,000 \text{ lb}$. Assume $a = 16 \text{ in.}$ and $b = 32 \text{ in.}$ Determine the normal stress in the rod at the following locations:

- (a) $x = 10 \text{ in.}$
- (b) $x = 30 \text{ in.}$

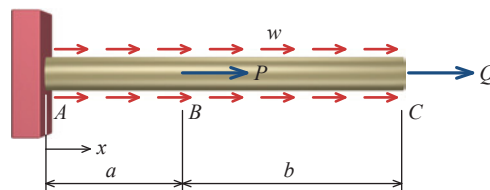

FIGURE P1.15

P1.16 Two 6-in.-wide wooden boards are to be joined by splice plates that will be fully glued onto the contact surfaces, as shown in Figure P1.16. The glue to be used can safely provide a shear strength of 120 psi. Determine the smallest allowable length L that can be used for the splice plates for an applied load of $P = 10,000 \text{ lb}$. Note that a gap of 0.5 in. is required between boards (1) and (2).

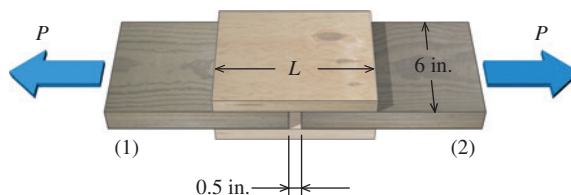

FIGURE P1.16

P1.17 For the clevis connection shown in Figure P1.17, determine the maximum applied load P that can be supported by the 10-mm-diameter pin if the average shear stress in the pin must not exceed 95 MPa.

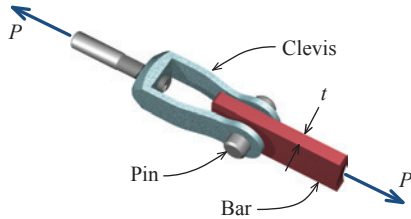

FIGURE P1.17

P1.18 For the connection shown in Figure P1.18, determine the average shear stress produced in the 3/8-in. diameter bolts if the applied load is $P = 2,500$ lb.

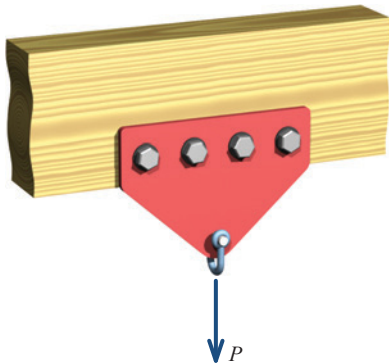

FIGURE P1.18

P1.19 The five-bolt connection shown in Figure P1.19 must support an applied load of $P = 265$ kN. If the average shear stress in the bolts must be limited to 120 MPa, determine the minimum bolt diameter that may be used for this connection.

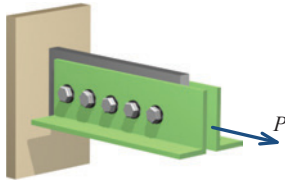

FIGURE P1.19

P1.20 A coupling is used to connect a 2-in.-diameter plastic pipe (1) to a 1.5-in.-diameter pipe (2), as shown in Figure P1.20. If

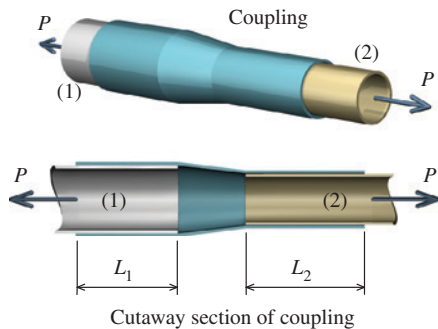

FIGURE P1.20

the average shear stress in the adhesive must be limited to 400 psi, determine the minimum lengths L_1 and L_2 required for the joint if the applied load P is 5,000 lb.

P1.21 A hydraulic punch press is used to punch a slot in a 0.50-in.-thick plate, as illustrated in Figure P1.21. If the plate shears at a stress of 30 ksi, determine the minimum force P required to punch the slot.

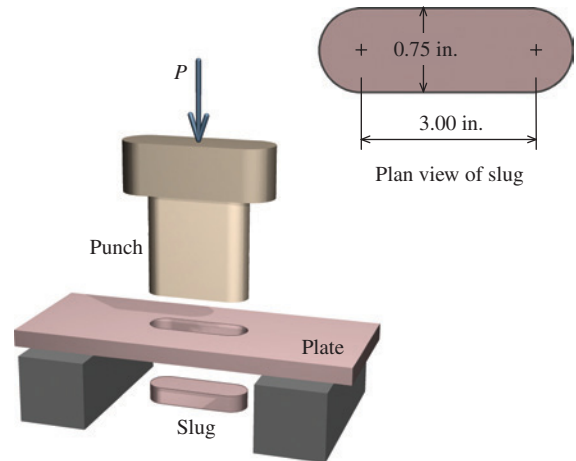

FIGURE P1.21

P1.22 The handle shown in Figure P1.22 is attached to a 40-mm-diameter shaft with a square shear key. The forces applied to the lever are $P = 1,300$ N. If the average shear stress in the key must not exceed 150 MPa, determine the minimum dimension a that must be used if the key is 25 mm long. The overall length of the handle is $L = 0.70$ m.

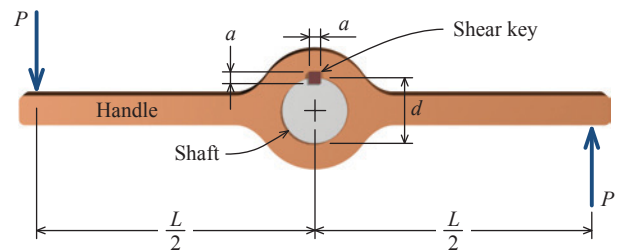

FIGURE P1.22

P1.23 An axial load P is supported by the short steel column shown in Figure P1.23. The column has a cross-sectional area of 14,500 mm². If the average normal stress in the steel column must not exceed 75 MPa, determine the minimum required dimension a so that the bearing stress between the base plate and the concrete slab does not exceed 8 MPa. Assume $b = 420$ mm.

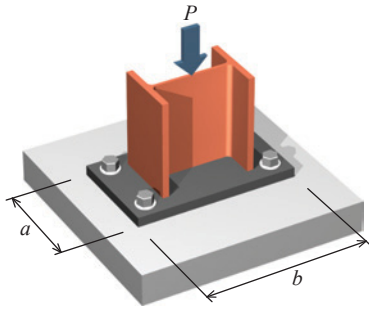

FIGURE P1.23

P1.24 The two wooden boards shown in Figure P1.24 are connected by a 0.5-in.-diameter bolt. Washers are installed under the head of the bolt and under the nut. The washer dimensions are $D = 2$ in. and $d = 5/8$ in. The nut is tightened to cause a tensile stress of 9,000 psi in the bolt. Determine the bearing stress between the washer and the wood.

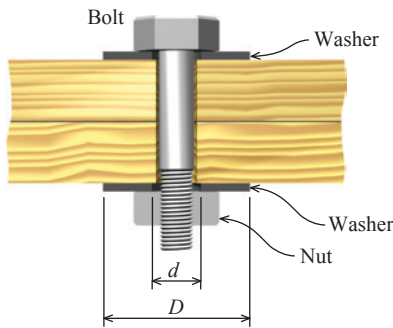

FIGURE P1.24

P1.25 For the beam shown in Figure P1.25, the allowable bearing stress for the material under the supports at A and B is $\sigma_b = 800$ psi. Assume $w = 2,100$ lb/ft, $P = 4,600$ lb, $a = 20$ ft, and $b = 8$ ft. Determine the size of square bearing plates required to support the loading shown. Dimension the plates to the nearest 1/2 in.

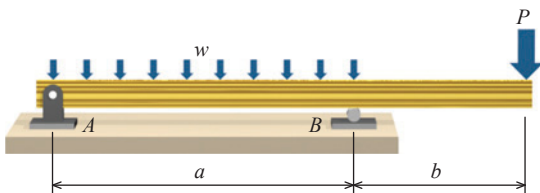

FIGURE P1.25

P1.26 The $d = 15$ -mm-diameter solid rod shown in Figure P1.26 passes through a $D = 20$ -mm-diameter hole in the support plate. When a load P is applied to the rod, the rod head rests on the support plate. The support plate has a thickness of $b = 12$ mm. The rod head has a diameter of $a = 30$ mm, and the head has a

thickness of $t = 10$ mm. If the normal stress produced in the rod by load P is 225 MPa, determine

- the bearing stress acting between the support plate and the rod head.
- the average shear stress produced in the rod head.
- the punching shear stress produced in the support plate by the rod head.

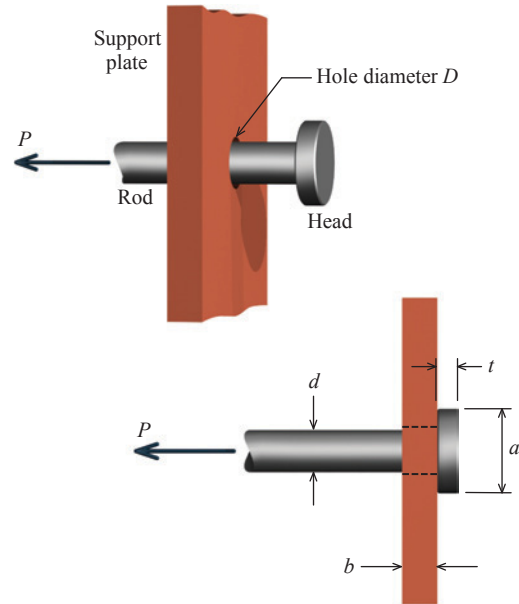

FIGURE P1.26

P1.27 The rectangular bar is connected to the support bracket with a circular pin, as shown in Figure P1.27. The bar width is $w = 1.75$ in. and the bar thickness is 0.375 in. For an applied load of $P = 5,600$ lb, determine the average bearing stress produced in the bar by the 0.625-in.-diameter pin.

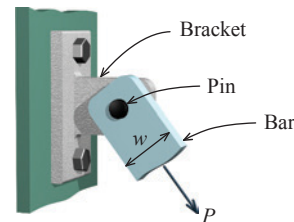

FIGURE P1.27

P1.28 The steel pipe column shown in Figure P1.28 has an outside diameter of 8.625 in. and a wall thickness of 0.25 in. The timber beam is 10.75 in. wide, and the upper plate has the same width. The load imposed on the column by the timber beam is 80 kips. Determine the following:

- the average bearing stress at the surfaces between the pipe column and the upper and lower steel bearing plates

- (b) the length L of the rectangular upper bearing plate if its width is 10.75 in. and the average bearing stress between the steel pipe and the wood beam is not to exceed 500 psi
- (c) the dimension a of the square lower bearing plate if the average bearing stress between the lower bearing plate and the concrete slab is not to exceed 900 psi

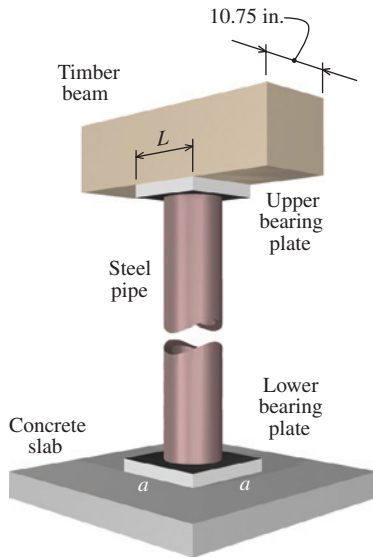

FIGURE P1.28

P1.29 A clevis-type pipe hanger supports an 8-in.-diameter pipe, as shown in Figure P1.29. The hanger rod has a diameter of 1/2 in. The bolt connecting the top yoke and the bottom strap has a diameter of 5/8 in. The bottom strap is 3/16 in. thick by 1.75 in. wide by 36 in. long. The weight of the pipe is 2,000 lb. Determine the following:

- (a) the normal stress in the hanger rod
- (b) the shear stress in the bolt
- (c) the bearing stress in the bottom strap

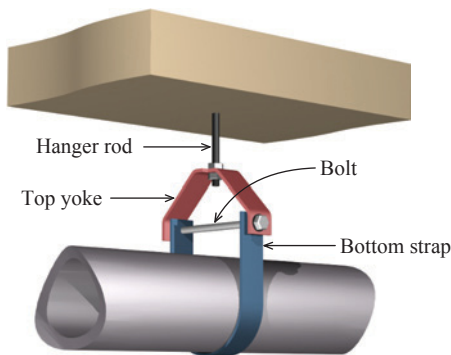

FIGURE P1.29

P1.30 Rigid bar ABC shown in Figure P1.30 is supported by a pin at bracket A and by tie rod (1). Tie rod (1) has a diameter of 5 mm, and it is supported by double-shear pin connections at B and D . The pin at bracket A is a single-shear connection. All pins are 7 mm in diameter. Assume $a = 600$ mm, $b = 300$ mm, $h = 450$ mm, $P = 900$ N, and $\theta = 55^\circ$. Determine the following:

- (a) the normal stress in rod (1)
- (b) the shear stress in pin B
- (c) the shear stress in pin A

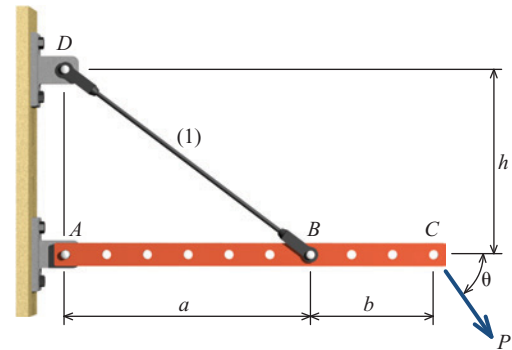

FIGURE P1.30

P1.31 The bell crank shown in Figure P1.31 is in equilibrium for the forces acting in rods (1) and (2). The bell crank is supported by a 10-mm-diameter pin at B that acts in single shear. The thickness of the bell crank is 5 mm. Assume $a = 65$ mm, $b = 150$ mm, $F_1 = 1,100$ N, and $\theta = 50^\circ$. Determine the following:

- (a) the shear stress in pin B
- (b) the bearing stress in the bell crank at B

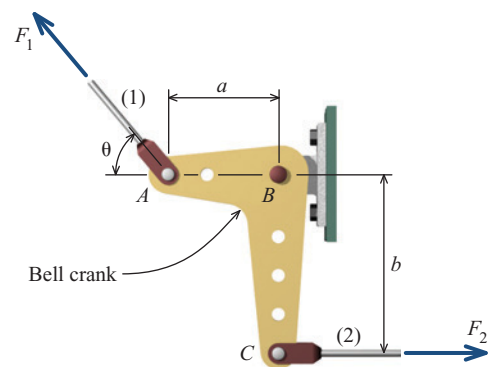

FIGURE P1.31

P1.32 The beam shown in Figure P1.32 is supported by a pin at C and by a short link AB . If $w = 30$ kN/m, determine the average shear stress in the pins at A and C . Each pin has a diameter of 25 mm. Assume $L = 1.8$ m and $\theta = 35^\circ$.

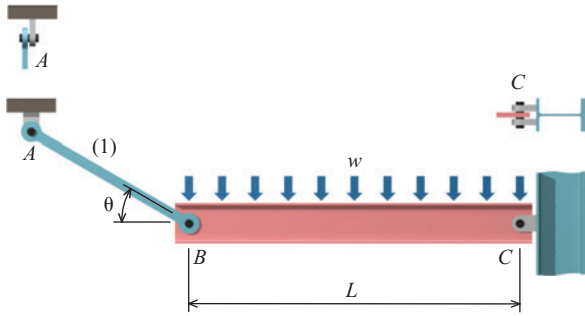

FIGURE P1.32

P1.33 The bell-crank mechanism shown in Figure P1.33 is in equilibrium for an applied load of $P = 7 \text{ kN}$ applied at A . Assume $a = 200 \text{ mm}$, $b = 150 \text{ mm}$, and $\theta = 65^\circ$. Determine the minimum diameter d required for pin B for each of the following conditions:

- The shear stress in the pin may not exceed 40 MPa .
- The bearing stress in the bell crank may not exceed 100 MPa .
- The bearing stress in the support bracket may not exceed 165 MPa .

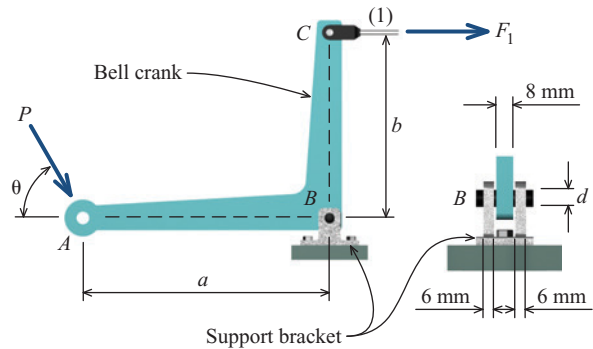

FIGURE P1.33

1.5 Stresses on Inclined Sections



MecMovies 1.11 is an animated presentation of the theory of stresses on an inclined plane.

In referencing planes, the orientation of the plane is specified by the normal to the plane. The inclined plane shown in Figure 1.7d is termed the n face because the n axis is the normal to this surface.

In previous sections, normal, shear, and bearing stresses on planes parallel and perpendicular to the axes of centrally loaded members were introduced. Stresses on planes inclined to the axes of axially loaded bars will now be considered.

Consider a prismatic bar subjected to an axial force P applied to the centroid of the bar (Figure 1.7a). Loading of this type is termed **uniaxial** since the force applied to the bar acts in one direction (i.e., either tension or compression). The cross-sectional area of the bar is A . To investigate the stresses that are acting internally in the material, we will cut through the bar at section $a-a$. The free-body diagram (Figure 1.7b) exposes the normal stress σ that is distributed over the cut section of the bar. The normal stress magnitude may be calculated from $\sigma = P/A$, provided that the stress is uniformly distributed. In this case, the stress will be uniform because the bar is prismatic and the force P is applied at the centroid of the cross section. The resultant of this normal stress distribution is equal in magnitude to the applied load P and has a line of action that is coincident with the axes of the bar, as shown. Note that there will be no shear stress τ since the cut surface is perpendicular to the direction of the resultant force.

Section $a-a$ is unique, however, because it is the only surface that is perpendicular to the direction of force P . A more general case would consider a section cut through the bar at an arbitrary angle. Consider a free-body diagram along section $b-b$ (Figure 1.7c). Because the stresses are the same throughout the entire bar, the stresses on the inclined surface must be uniformly distributed. Since the bar is in equilibrium, the resultant of the uniformly distributed stress must equal P even though the stress acts on a surface that is inclined.

The orientation of the inclined surface can be defined by the angle θ between the x axis and an axis *normal* to the plane, which is the n axis, as shown in Figure 1.7d. A positive angle θ is defined as a counterclockwise rotation from the x axis to the n axis. The t axis is *tangential* to the cut surface, and the $n-t$ axes form a right-handed coordinate system.

To investigate the stresses acting on the inclined plane (Figure 1.7d), the components of resultant force P acting perpendicular and parallel to the plane must be computed. Using θ as defined previously, the perpendicular force component (i.e., normal force) is $N = P \cos \theta$, and the parallel force component (i.e., shear force) is $V = -P \sin \theta$. (The negative sign indicates that the shear force acts in the $-t$ direction, as shown in Figure 1.7d.) The area of

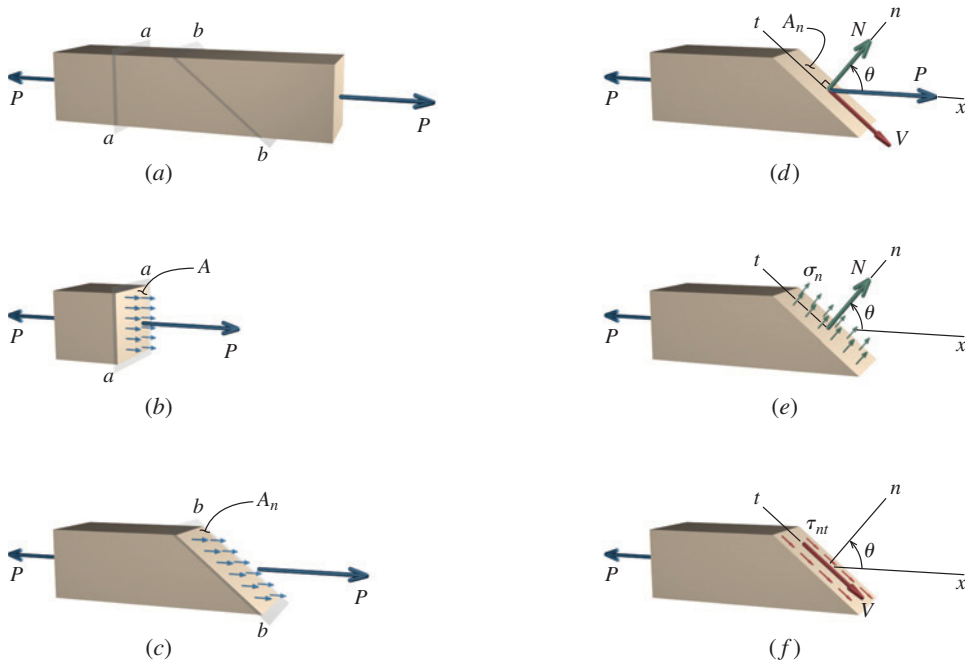

FIGURE 1.7 (a) Prismatic bar subjected to axial force P . (b) Normal stresses on section a – a . (c) Stresses on inclined section b – b . (d) Force components acting perpendicular and parallel to inclined plane. (e) Normal stresses acting on inclined plane. (f) Shear stresses acting on inclined plane.

the inclined plane $A_n = A/\cos \theta$, where A is the cross-sectional area of the axially loaded member. The normal and shear stresses acting on the inclined plane (Figures 1.7e and 1.7f) can now be determined by dividing the force component by the area of the inclined plane:

$$\sigma_n = \frac{N}{A_n} = \frac{P \cos \theta}{A/\cos \theta} = \frac{P}{A} \cos^2 \theta = \frac{P}{2A} (1 + \cos 2\theta) \quad (1.8)$$

$$\tau_{nt} = \frac{V}{A_n} = \frac{-P \sin \theta}{A/\cos \theta} = -\frac{P}{A} \sin \theta \cos \theta = -\frac{P}{2A} \sin 2\theta \quad (1.9)$$

Since both the area of the inclined surface A_n and the values for the normal and shear forces N and V on the surface depend on the angle of inclination θ , the normal and shear stresses σ_n and τ_{nt} also depend on the angle of inclination θ of the plane. *This dependence of stress on both force and area means that stress is not a vector quantity*; therefore, the laws of the vector addition do not apply to stresses.

A graph showing the values of σ_n and τ_{nt} as a function of θ is given in Figure 1.8. These plots indicate that σ_n is largest when θ is 0° or 180° , that τ_{nt} is largest when θ is

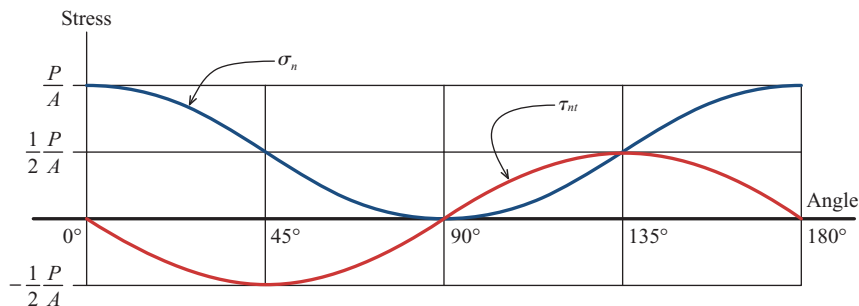

FIGURE 1.8 Variation of normal and shear stress as a function of inclined plane orientation θ .

45° or 135°, and also that $\tau_{\max} = \sigma_{\max}/2$. Therefore, the maximum normal and shear stresses in an axial member that is subjected to an uniaxial tension or compression force applied through the centroid of the member (termed a **centric loading**) are

$$\sigma_{\max} = \frac{P}{A} \quad \text{and} \quad \tau_{\max} = \frac{P}{2A} \quad (1.10)$$

Note that the normal stress is either maximum or minimum on planes for which the shear stress is zero. It can be shown that the shear stress is always zero on the planes of maximum or minimum normal stress. The concepts of maximum and minimum normal stress and maximum shear stress for more general cases will be treated in later sections of this book.

The plot of normal and shear stresses for axial loading, shown in Figure 1.8, indicates that the sign of the shear stress changes when θ is greater than 90°. The magnitude of the shear stress for any angle θ , however, is the same as that for $90^\circ + \theta$. The sign change merely indicates that the shear force V changes direction.

Significance

Although one might think that there is only a single stress in a material (particularly in a simple axial member), this discussion has demonstrated that there are many different combinations of normal and shear stress in a solid object. The magnitude and direction of the normal and shear stresses at any point depend on the orientation of the plane being considered.

Why Is This Important? In designing a component, an engineer must be mindful of all possible combinations of normal stress σ_n and shear stress τ_{nt} that exist on internal surfaces of the object, not just the most obvious ones. Further, different materials are sensitive to different types of stress. For example, laboratory tests on specimens loaded in uniaxial tension reveal that brittle materials tend to fail in response to the magnitude of normal stress. These materials fracture on a transverse plane (i.e., a plane such as section $a-a$ in Figure 1.7a). Ductile materials, on the other hand, are sensitive to the shear stress magnitude. A ductile material loaded in uniaxial tension will fracture on a 45° plane since the maximum shear stress occurs on this surface.

1.6 Equality of Shear Stresses on Perpendicular Planes

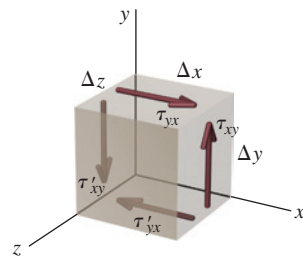

FIGURE 1.9 Shear stresses acting on a small volume element of material.

If an object is in equilibrium, then any portion of the object that one chooses to examine must also be in equilibrium, no matter how small that portion may be. Therefore, let us consider a small-volume element of material that is subjected to shear stress, as shown in Figure 1.9. The front and rear faces of this small element are free of stress.

Equilibrium involves forces, not stresses. For us to consider the equilibrium of this element, we must find the forces produced by the stresses that act on each face, by multiplying the stress acting on each face by the area of the face. For example, the horizontal force acting on the top face of this element is given by $\tau_{yx}\Delta x\Delta z$, and the vertical force acting on the right face of this element is given by $\tau_{xy}\Delta y\Delta z$. Equilibrium in the horizontal direction gives

$$\Sigma F_x = \tau_{yx}\Delta x\Delta z - \tau'_{yx}\Delta x\Delta z = 0 \quad \therefore \tau_{yx} = \tau'_{yx}$$

and equilibrium in the vertical direction gives

$$\Sigma F_y = \tau_{xy}\Delta y\Delta z - \tau'_{xy}\Delta y\Delta z = 0 \quad \therefore \tau_{xy} = \tau'_{xy}$$

Finally, taking moments about the z axis gives

$$\Sigma M_z = (\tau_{xy} \Delta y \Delta z) \Delta x - (\tau_{yx} \Delta x \Delta z) \Delta y = 0 \quad \therefore \tau_{xy} = \tau_{yx}$$

Therefore, equilibrium requires that

$$\tau_{xy} = \tau_{yx} = \tau'_{xy} = \tau'_{yx} = \tau$$

In other words, if a shear stress acts on one plane in the object, then equal-magnitude shear stresses act on three other planes. The shear stresses must be oriented either as shown in Figure 1.9 or in the opposite directions on each face.

Shear stress arrows on adjacent faces act either toward each other or away from each other. In other words, the arrows are arranged head-to-head or tail-to-tail—never head-to-tail—on intersecting perpendicular planes.

EXAMPLE 1.9

A 120-mm-wide steel bar with a butt-welded joint, as shown, will be used to carry an axial tension load of $P = 180$ kN. If the normal and shear stresses on the plane of the butt weld must be limited to 80 MPa and 45 MPa, respectively, determine the minimum thickness required for the bar.

Plan the Solution

Either the normal stress limit or the shear stress limit will dictate the area required for the bar. There is no way to know beforehand which stress will control; therefore, both possibilities must be checked. The minimum cross-sectional area required for each limit must be determined. Using the larger of these two results, the minimum bar thickness will be determined. For illustration, this example will be worked in two ways:

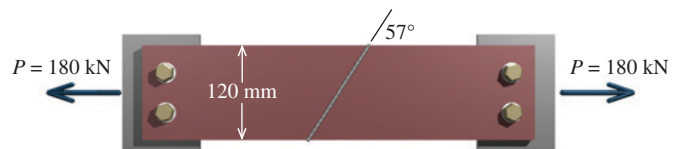

- by directly using the normal and shear components of force P ,
- by using Equations (1.8) and (1.9).

SOLUTION

(a) Solution Using Normal and Shear Force Components

Consider a free-body diagram (FBD) of the left half of the member. Resolve the axial force $P = 180$ kN into a force component N perpendicular to the weld and a force component V parallel to the weld.

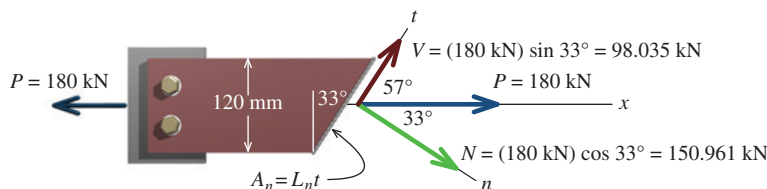

The minimum cross-sectional area of the weld A_n needed to limit the normal stress on the weld to 80 MPa can be computed from

$$\sigma_n = \frac{N}{A_n} \quad \therefore A_n \geq \frac{(150.961 \text{ kN})(1,000 \text{ N/kN})}{80 \text{ N/mm}^2} = 1,887.013 \text{ mm}^2$$

Similarly, the minimum cross-sectional area of the weld A_n needed to limit the shear stress on the weld to 45 MPa can be computed from

$$\tau_{nt} = \frac{V}{A_n} \quad \therefore A_n \geq \frac{(98.035 \text{ kN})(1,000 \text{ N/kN})}{45 \text{ N/mm}^2} = 2,178.556 \text{ mm}^2$$

To satisfy both normal and shear stress limits, the minimum cross-sectional area A_n needed for the weld is $A_n = 2,178.556 \text{ mm}^2$. Next, we can determine the length of the weld L_n along the inclined surface. From the geometry of the surface,

$$\cos 33^\circ = \frac{120 \text{ mm}}{L_n} \quad \therefore L_n = \frac{120 \text{ mm}}{\cos 33^\circ} = 143.084 \text{ mm}$$

Therefore, to provide the necessary weld area, the minimum thickness is computed as

$$t_{\min} \geq \frac{2,178.556 \text{ mm}^2}{143.084 \text{ mm}} = 15.23 \text{ mm} \quad \text{Ans.}$$

(b) Solution Using Equations (1.8) and (1.9)

Determine the angle θ needed for Equations (1.8) and (1.9). The angle θ is defined as the angle between the transverse cross section (i.e., the section perpendicular to the applied load) and the inclined surface, with positive angles defined in a counterclockwise direction. Although the butt weld angle is labeled 57° in the problem sketch, this is not the value needed for θ . For use in the equations, $\theta = -33^\circ$.

The normal and shear stresses on the inclined plane can be computed from

$$\sigma_n = \frac{P}{A} \cos^2 \theta \quad \text{and} \quad \tau_{nt} = -\frac{P}{A} \sin \theta \cos \theta$$

According to the 80-MPa normal stress limit, the minimum cross-sectional area required for the bar is

$$A_{\min} \geq \frac{P}{\sigma_n} \cos^2 \theta = \frac{(180 \text{ kN})(1,000 \text{ N/kN})}{80 \text{ N/mm}^2} \cos^2(-33^\circ) = 1,582.58 \text{ mm}^2$$

Similarly, the minimum area required for the bar, based on the 45-MPa shear stress limit, is

$$A_{\min} \geq -\frac{P}{\tau_{nt}} \sin \theta \cos \theta = -\frac{(180 \text{ kN})(1,000 \text{ N/kN})}{45 \text{ N/mm}^2} \sin(-33^\circ) \cos(-33^\circ) = 1,827.09 \text{ mm}^2$$

Note: Here we are concerned with force and area magnitudes. If the area calculations had produced a negative value, we would have considered only the absolute value.

To satisfy both stress limits, the larger of the two areas must be used. Since the steel bar is 120 mm wide, the minimum bar thickness must be

$$t_{\min} \geq \frac{1,827.09 \text{ mm}^2}{120 \text{ mm}} = 15.23 \text{ mm} \quad \text{Ans.}$$



MecMovies Example M1.12

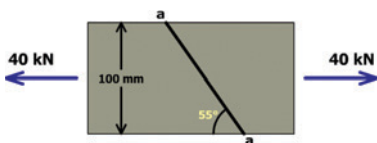

The steel bar shown has a 100-mm by 25-mm rectangular cross section. If an axial force of $P = 40 \text{ kN}$ is applied to the bar, determine the normal and shear stresses acting on the inclined surface $a-a$.



MecMovies Example M1.13

The steel bar shown has a 50-mm by 10-mm rectangular cross section. The allowable normal and shear stresses on the inclined surface must be limited to 40 MPa and 25 MPa, respectively. Determine the magnitude of the maximum axial force of P that can be applied to the bar.

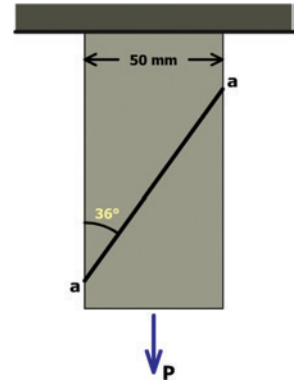

MecMovies Exercises

M1.12 The bar has a rectangular cross section. For a given load P , determine the force components perpendicular and parallel to section $a-a$, the inclined surface area, and the normal and shear stress magnitudes acting on surface $a-a$.

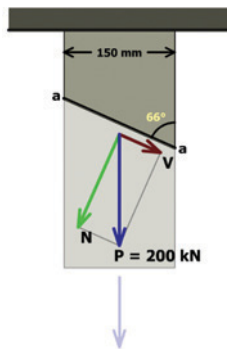

FIGURE M1.12

M1.13 The bar has a rectangular cross section. The allowable normal and shear stresses on inclined surface $a-a$ are given. Determine the magnitude of the maximum axial force P that can be applied to the bar and determine the actual normal and shear stresses acting on inclined plane $a-a$.

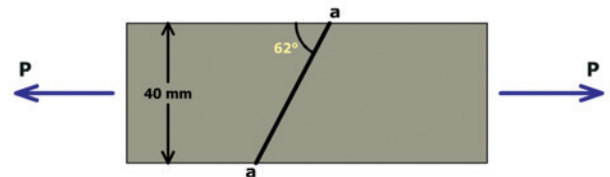

FIGURE M1.13

PROBLEMS

P1.34 A structural steel bar with a 25 mm \times 75 mm rectangular cross section is subjected to an axial load of 150 kN. Determine the maximum normal and shear stresses in the bar.

P1.35 A steel rod of circular cross section will be used to carry an axial load of 92 kips. The maximum stresses in the rod must be limited to 30 ksi in tension and 12 ksi in shear. Determine the required diameter for the rod.

P1.36 An axial load P is applied to the rectangular bar shown in Figure P1.36. The cross-sectional area of the bar is 400 mm^2 . Determine the normal stress perpendicular to plane AB and the shear stress parallel to plane AB if the bar is subjected to an axial load of $P = 70 \text{ kN}$.

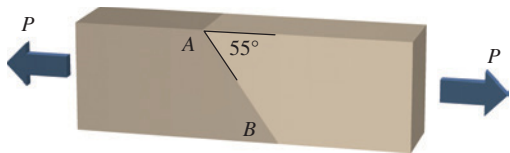

FIGURE P1.36

P1.37 An axial load P is applied to the 1.75-in.-by-0.75-in. rectangular bar shown in Figure P1.37. Determine the normal stress perpendicular to plane AB and the shear stress parallel to plane AB if the bar is subjected to an axial load of $P = 18 \text{ kips}$.

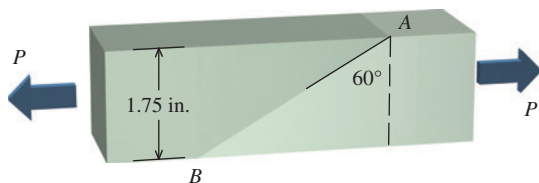

FIGURE P1.37

P1.38 A compression load of $P = 80 \text{ kips}$ is applied to a 4-in.-by-4-in. square post, as shown in Figure P1.38. Determine the normal stress perpendicular to plane AB and the shear stress parallel to plane AB .

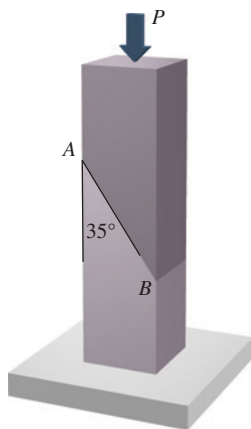

FIGURE P1.38

P1.39 Specifications for the $50 \text{ mm} \times 50 \text{ mm}$ square bar shown in Figure P1.39 require that the normal and shear stresses on plane AB not exceed 120 MPa and 90 MPa , respectively. Determine the maximum load P that can be applied without exceeding the specifications.

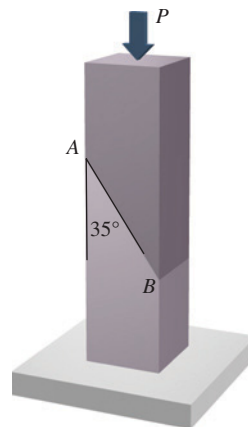

FIGURE P1.39

P1.40 Specifications for the 6 in. \times 6 in. square post shown in Figure P1.40 require that the normal and shear stresses on plane AB not exceed 800 psi and 400 psi , respectively. Determine the maximum load P that can be applied without exceeding the specifications.

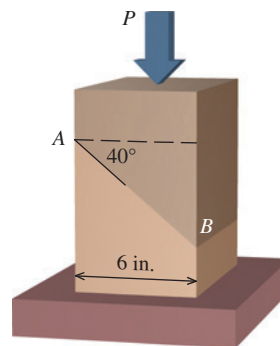

FIGURE P1.40

P1.41 A 90-mm-wide bar will be used to carry an axial tension load of 280 kN , as shown in Figure P1.41. The normal and shear stresses on plane AB must be limited to 150 MPa and 100 MPa , respectively. Determine the minimum thickness t required for the bar.

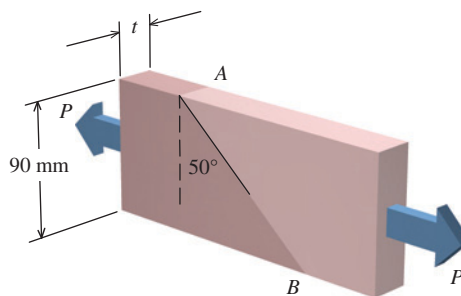

FIGURE P1.41

P1.42 A rectangular bar having width $w = 6.00$ in. and thickness $t = 1.50$ in. is subjected to a tension load P , as shown in Figure P1.42/43. The normal and shear stresses on plane AB must not exceed 16 ksi and 8 ksi, respectively. Determine the maximum load P that can be applied without exceeding either stress limit.

P1.43 In Figure P1.42/43, a rectangular bar having width $w = 1.25$ in. and thickness t is subjected to a tension load of $P = 30$ kips. The normal and shear stresses on plane AB must not exceed 12 ksi and 8 ksi, respectively. Determine the minimum thickness t required for the bar.

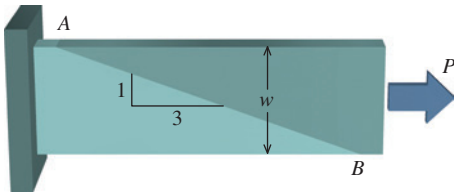

FIGURE P1.42/43

P1.44 The rectangular bar has a width of $w = 3.00$ in. and a thickness of $t = 2.00$ in. The normal stress on plane AB of the rectangular block shown in Figure P1.44/45 is 6 ksi (C) when the load P is applied. Determine

- the magnitude of load P .
- the shear stress on plane AB .
- the maximum normal and shear stresses in the block at any possible orientation.

P1.45 The rectangular bar has a width of $w = 100$ mm and a thickness of $t = 75$ mm. The shear stress on plane AB of the rectangular block shown in Figure P1.44/45 is 12 MPa when the load P is applied. Determine

- the magnitude of load P .
- the normal stress on plane AB .
- the maximum normal and shear stresses in the block at any possible orientation.

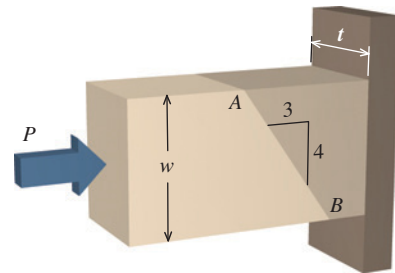

FIGURE P1.44/45