

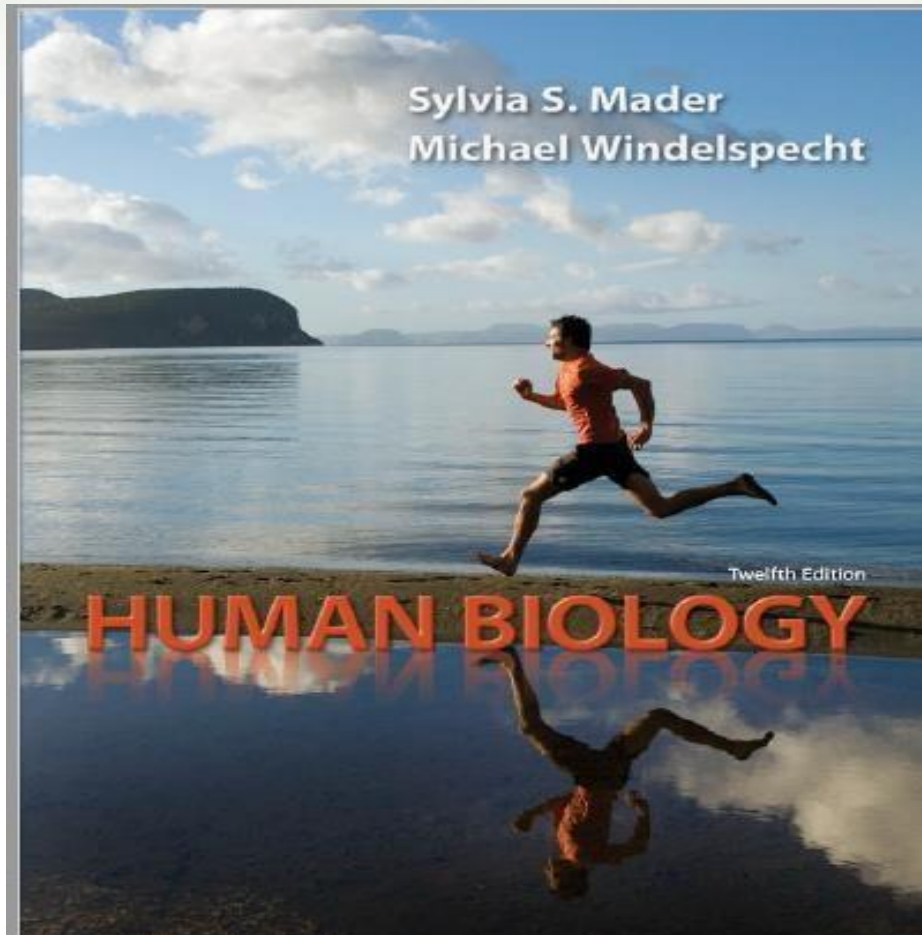

**Biology**  
**Lecture Biology**  
**Lecture I – Introduction**

**Assist Prof. Dr.Rehab A. H. Al-Baker**

# Reference



# Definition

- ❑ The science of biology is the study of living organisms and their environments. All living things share several basic characteristics. Living things (1) are organized, (2) acquire materials and energy, (3) reproduce, (4) grow and develop, (5) are homeostatic, (6) respond to stimuli.
- ❑ It covers all aspect of the study of living creatures like **occurrence**, **classification**, ecology, economic importance, organization, internal structure, nutrition, health and other body functions, reproduction, life history, inheritance and origin. The term biology is often replaced by the term **life sciences** or **biological sciences**.

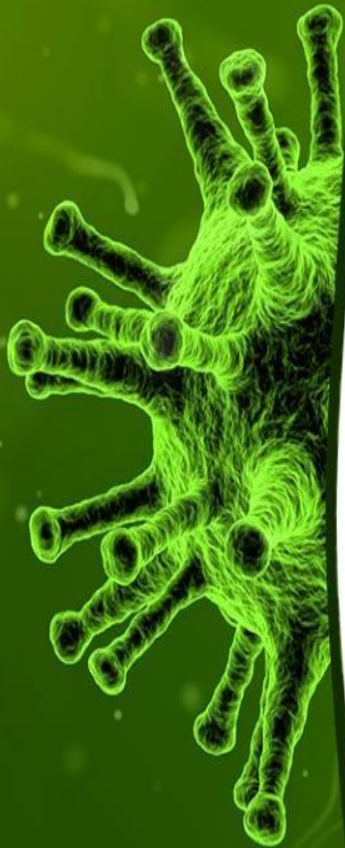



# Main branches of Biology

## **Anatomy**

It is the study of internal structure which can be observed with unaided eye after dissection

## **Histology**

It is the study of tissue organization and structure as observed through light microscope.



# Main branches of Biology

## **Cytology**

- It is the study of form and structure of cells including the behavior of nucleus and other organelles.

## **Molecular Biology**

- It is the study of the nature, physicochemical organization, synthesis working and interaction of bio-molecules that bring about and control various activities of the protoplasm.



# Main branches of Biology

## Physiology

- It is the study of different types of body functions and processes.

## Embryology

It is the study of fertilization, growth, division and differentiation of the **zygote** into embryo or early development of living beings before the attainment of structure and size of the offspring.



# Main branches of Biology

## Genetics

- It is the study of inheritance of characters or heredity and variations. Heredity is the study of expression and transmission of traits from parents to offspring.

## Virology

It is the study of viruses in all their aspects.

# The Characteristics of Life

**. LIVING THINGS ARE ORGANIZED**

**. LIVING THINGS ACQUIRE MATERIALS AND ENERGY**

**STABILITY AND HOMEOSTASI**

**. LIVING THINGS REPRODUCE AND DEVELOP**

**RESPONSIVENESS**



A background image showing a microscopic view of biological structures, possibly cells or tissues, with a green and blue color scheme. The structures are complex and interconnected, with some showing a fibrous or network-like appearance. The overall tone is scientific and detailed.

# The Characteristics of Life

## I. LIVING THINGS ARE ORGANIZED

**Atoms** join together to form the **molecules** that make up a cell. A cell is the smallest structural and functional unit of an organism. Some organisms are single cells. Humans are multicellular because they are composed of many different types of cells. A nerve cell is one of the types of cells in the human body. It has a structure suitable to conducting a nerve impulse. A **tissue** is a group of similar cells that perform a particular function. Nervous tissue is composed of millions of nerve cells that transmit signals to all parts of the body. Several types of tissues make up an organ, and each organ belongs to an organ system. The organs of an organ system work together to accomplish a common purpose. The brain works with the spinal cord to send commands to body parts by way of nerves. Organisms, such as trees and humans, are a collection of organ systems. The levels of biological organization extend beyond the individual. All the members of one species (group of interbreeding organisms) in a particular area belong to a population. A tropical grassland may have a population of zebras, acacia trees, and humans, for example. The interacting populations of the grasslands make up a community. The community of populations interacts with the physical environment to form an ecosystem. Finally, all the Earth's ecosystems make up the biosphere



**Figure 1.2 Levels of biological organization.**  
 Living organisms are organized. The smallest unit of living organisms is the cell. The sum of all living things—and the locations that they inhabit—is called the biosphere.

**Biosphere**  
 Regions of the Earth's crust, waters, and atmosphere inhabited by living things

↑

**Ecosystem**  
 A community plus the physical environment

↑

**Community**  
 Interacting populations in a particular area

↑

**Population**  
 Organisms of the same species in a particular area

↑

**Organism**  
 An individual, complex individuals contain organ systems

↑

**Organ System**  
 Composed of several organs working together

↑

**Organ**  
 Composed of tissues functioning together for a specific task

↑

**Tissue**  
 A group of cells with a common structure and function

↑

**Cell**  
 The structural and functional unit of all living things

↑

**Molecule**  
 Union of two or more atoms of the same or different elements

↑

**Atom**  
 Smallest unit of an element composed of electrons, protons, and neutrons

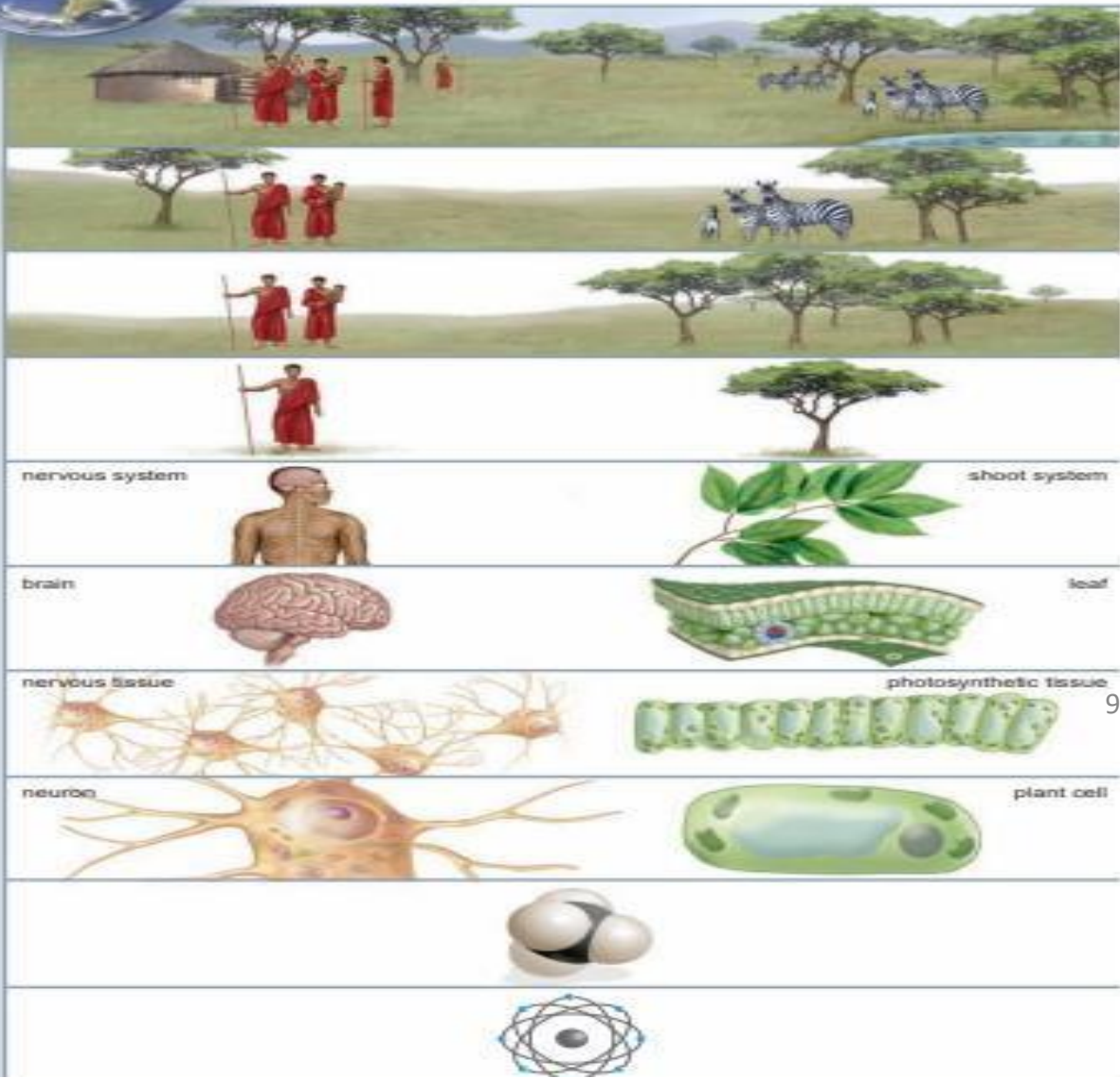

The background of the slide features a microscopic view of biological structures. On the left, there are several spherical particles with numerous protruding spikes, resembling viruses. In the center and right, there are larger, more complex structures with multiple branching or tubular protrusions, which could be cross-sections of cells or other biological organisms. The overall color scheme is a mix of green and blue, with a dark background.

## The Characteristics of Life

### II. LIVING THINGS ACQUIRE MATERIALS AND ENERGY

- ✓ Humans, like all living organisms, cannot maintain their organization or carry on life's activities without an outside source of materials and energy.
- ✓ Food provides nutrient molecules, which are used as building blocks for energy.
- ✓ Some nutrient molecules are broken down completely to provide the necessary energy to convert other nutrient molecules into the parts and products of cells. The term metabolism describes all of the chemical reactions that occur within a cell.
- ✓ The ultimate source of energy for the majority of life on Earth is the **sun**. Plants, algae, and some bacteria are able to harvest the energy of the sun and convert it to chemical energy by a process called **photosynthesis**. Photosynthesis produces **organic molecules, such as sugars**, that serve as the basis of the food chain for many other organisms, including humans and all other animals.

The background of the slide features a green-tinted microscopic image of biological structures, including what appears to be a virus on the left and several elongated, branching cellular or tissue-like structures in the center and right.

## The Characteristics of Life

### III. STABILITY AND HOMEOSTASIS

- ✓ The ability of a cell or an organism to maintain an internal environment that operates under specific conditions is called **homeostasis**. In humans, many of our organ systems work to maintain homeostasis. For example, human body temperature normally fluctuates slightly between 36.5 and 37.5°C (97.7 and 99.5°F) during the day. **Temperature, water content, chemical content, etc. must be maintained.**
- ✓ This text emphasizes how all the systems of the human body help maintain homeostasis. The digestive system takes in nutrients, and the respiratory system exchanges gases with the environment. The cardiovascular system distributes nutrients and oxygen to the cells and picks up their wastes. The metabolic waste products of cells are excreted by the urinary system. The work of the nervous and endocrine systems is critical because these systems coordinate the functions of the other systems.



# The Characteristics of Life

## IV. LIVING THINGS REPRODUCE AND DEVELOP

- ✓ Reproduction is a fundamental characteristic of life. Cells come into being only from pre-existing cells, and all living things have parents. When living things reproduce, they create a copy of themselves and ensure the continuance of their own kind. Following the fertilization of the egg by a sperm cell, the resulting zygote undergoes a rapid period of growth and development.
- ✓ The purpose of reproduction is to pass on a copy of the genetic information to the offspring. DNA contains the hereditary information that directs not only the structure of each cell but also its function. The information in the DNA is contained within genes, short sequences of hereditary material that specify the instructions for a specific trait. Before reproduction occurs, DNA is replicated so that an exact copy of each gene may be passed on to the offspring



# The Characteristics of Life

## IV. LIVING THINGS REPRODUCE AND DEVELOP

- ✓ Reproduction is a fundamental characteristic of life. Cells come into being only from pre-existing cells, and all living things have parents. When living things reproduce, they create a copy of themselves and ensure the continuance of their own kind. Following the fertilization of the egg by a sperm cell, the resulting zygote undergoes a rapid period of growth and development.
- ✓ The purpose of reproduction is to pass on a copy of the genetic information to the offspring. DNA contains the hereditary information that directs not only the structure of each cell but also its function. The information in the DNA is contained within genes, short sequences of hereditary material that specify the instructions for a specific trait. Before reproduction occurs, DNA is replicated so that an exact copy of each gene may be passed on to the offspring



# The Characteristics of Life

## V. RESPONSIVENESS

- ✓ Respond to stimuli in the external environment Detect and respond to changes in light, heat, sound and chemical and mechanical contact.
- ✓ when we quickly remove a hand from a hot stove. Certain sensory receptors also detect a change in the internal environment, and then the central nervous system brings about an appropriate response. When you are startled by a loud noise, your heartbeat increases, which causes your blood pressure to increase. If blood pressure rises too high, the brain directs blood vessels to dilate, helping to restore normal blood pressure



## Humans Are Related to Other Animals

Biologists classify living things as belonging to one of three **domains**

- ✓ **Bacteria**
- ✓ **Archaea**
- ✓ **Eukarya**

domain Bacteria and domain Archaea, contain prokaryotes, one-celled organisms that lack a nucleus. Organisms in the third domain, Eukarya, are classified as being members of one of four kingdoms — **plants**, **fungi**, **animals**, and **protists**. Most organisms in kingdom Animalia are invertebrates, such as the earthworm, insects, and mollusks. Vertebrates are animals that have a nerve cord protected by a vertebral column, which gives them their name. Fish, reptiles, amphibians, and birds are all vertebrates. Vertebrates with hair or fur and mammary glands are classified as mammals. Humans, raccoons, seals, and meerkats are examples of mammals.



Domain Eukarya; Kingdom Protists

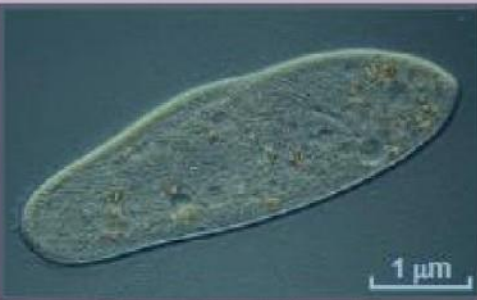

- Algae, protozoans, slime molds, and water molds
- Complex single cell (sometimes filaments, colonies, or even multicellular)
- Absorb, photosynthesize, or ingest food

*Paramecium*, a unicellular protozoan

Domain Eukarya; Kingdom Animals



*Vulpes*, a red fox

- Sponges, worms, insects, fishes, frogs, turtles, birds, and mammals
- Multicellular with specialized tissues containing complex cells
- Ingest food

Domain Eukarya; Kingdom Fungi



- Molds, mushrooms, yeasts, and ringworms
- Mostly multicellular filaments with specialized, complex cells
- Absorb food

*Coprinus*, a shaggy mane mushroom

Domain Archaea



- Prokaryotic cells
- extreme environments
- Absorb or ingest food

## Science as a Process

The scientific method consists of

- making an observation;
- formulating a hypothesis;
- carrying out experiments and observations;
- coming to a conclusion; and
- presenting results of the study for peer review

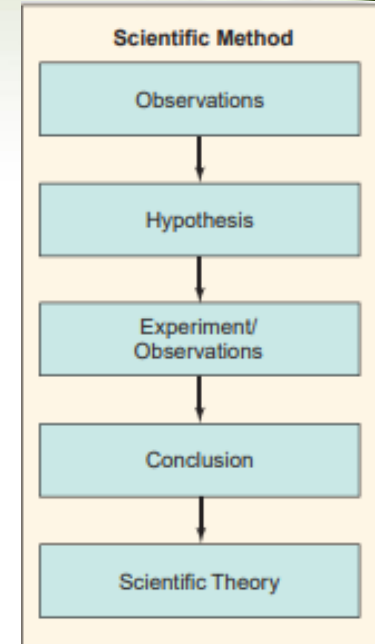

A decorative header image showing a microscopic view of virus particles, likely influenza, with their characteristic surface spikes. The image is rendered in shades of green and blue, set against a dark background.

## How to Do a Controlled Study

- A large number of subjects are divided randomly into groups.
- The test group/s is/ are exposed to an experimental variable.
- A control group is not exposed to an experimental variable and is given a placebo.
- All groups are otherwise treated the same, and it is best if the subjects and the technicians do not know what group they are in.
- The results and conclusion are published in a scientific journal.

# Thanks

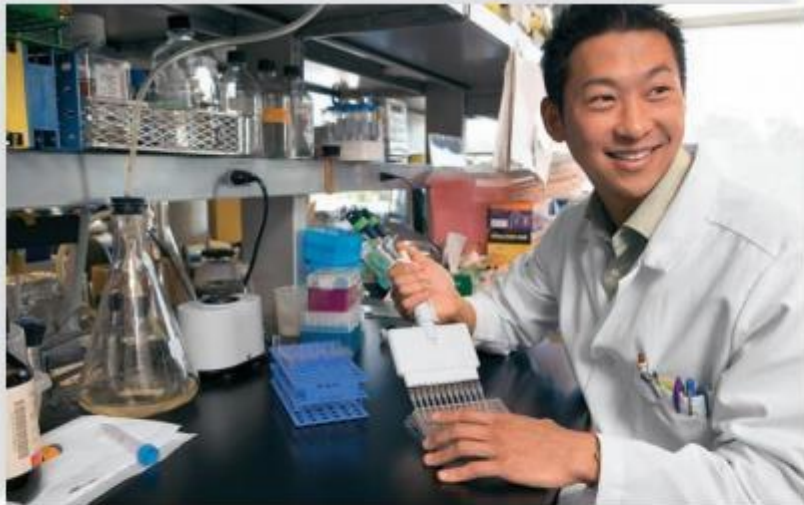

a.

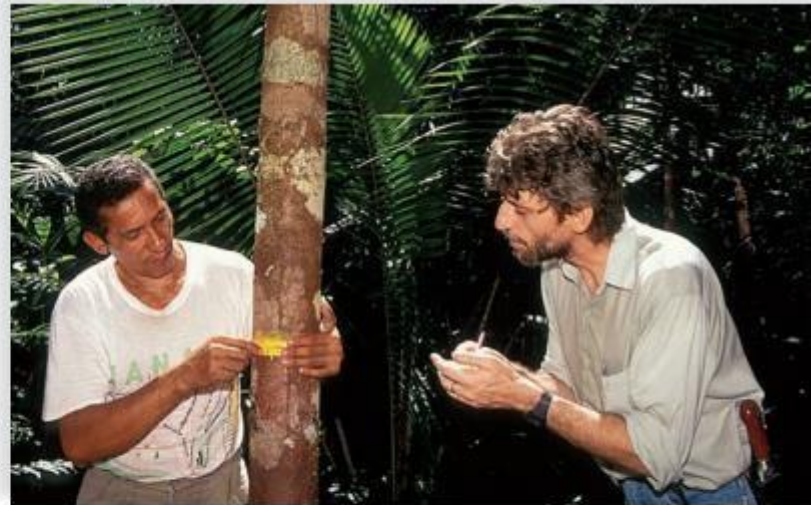

b.

**Figure 1.12** Biologists work in many environments.

Data collection can be done (a) in the laboratory or (b) in the field. Biologists discover basic information about the natural world, including the effects of technology on human health and the environment.



# **Biology**

## **Lecture II – The cell**

**Assist Prof. Dr.Rehab A. H. Al-Baker**

**TABLE 1.1:** Major Organ Systems of the Human Body

<b>Organ System</b>	<b>Major Tissues and Organs</b>	<b>Function</b>
Cardiovascular	Heart; blood vessels; blood	Transports oxygen, hormones, and nutrients to the body cells. Moves wastes and carbon dioxide away from cells.
Lymphatic	Lymph nodes; lymph vessels	Defend against infection and disease, moves lymph between tissues and the blood stream.
Digestive	Esophagus; stomach; small intestine; large intestine	Digests foods and absorbs nutrients, minerals, vitamins, and water.
Endocrine	Pituitary gland, hypothalamus; adrenal glands; ovaries; testes	Produces <b>hormones</b> that communicate between cells.
Integumentary	Skin, hair, nails	Provides protection from injury and water loss, physical defense against infection by microorganisms, and temperature control.
Muscular	Cardiac (heart) muscle; skeletal muscle; smooth muscle; tendons	Involved in movement and heat production.
Nervous	Brain, spinal cord; nerves	Collects, transfers, and processes information.
Reproductive	Female: uterus; vagina; fallopian tubes; ovaries Male: penis; testes; seminal vesicles	Produces gametes (sex cells) and sex hormones.
Respiratory	Trachea, larynx, pharynx, lungs	Brings air to sites where gas exchange can occur between the blood and cells (around body) or blood and air (lungs).
Skeletal	Bones, cartilage; ligaments	Supports and protects soft tissues of body; produces blood cells; stores minerals.
Urinary	Kidneys; urinary bladder	Removes extra water, salts, and waste products from blood and body; controls pH; controls water and salt balance.
Immune	Bone marrow; spleen; white blood	Defends against diseases.

# CELL

Most cells are small and can be seen only under a microscope. The small size of cells means that they are measured using the smaller units of the metric system, such as the *micrometer* ( $\mu\text{m}$ ). A micrometer is 1/1,000 millimeter. The micrometer is the common unit of measurement for people who use microscopes professionally

❑ Most human cells are about 100  $\mu\text{m}$  in diameter.

# The Cell Theory

As stated by the **cell theory**,

- *a cell is the basic unit of life*. Nothing smaller than a cell is alive. A unicellular organism exhibits the characteristics of life.
- *All living things are made up of cells.*

Is there any tissue in the human body not composed of cells? At first, you might be inclined to say that bone is not composed of cells.



However, if you were to examine bone tissue under the microscope, you would be able to see that it, too, is composed of cells surrounded by material they have deposited. Cells look different—a blood cell looks different than a nerve cell.

**Figure**      Cells vary in structure and function. A cell's structure is related to its function. Despite differences in appearance, all exchange substances with their environment.

red blood cell

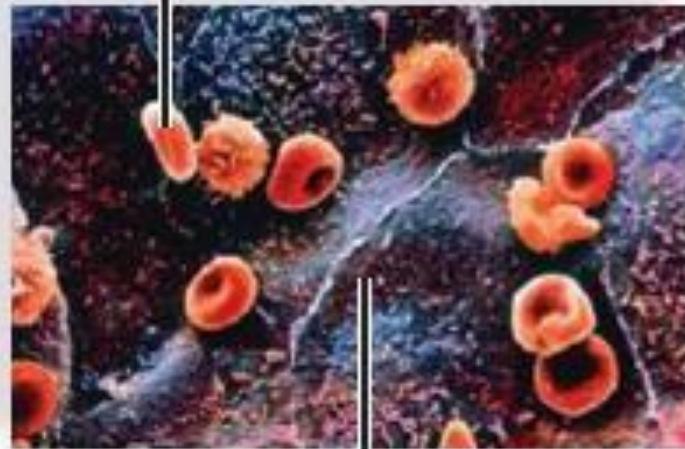

blood vessel cell

nerve cell

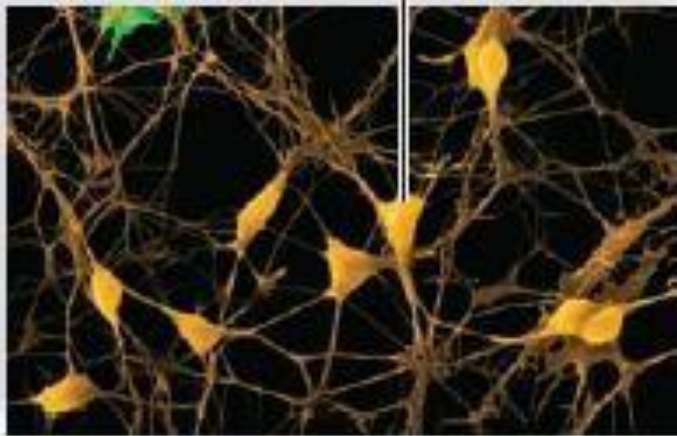

cartilage cell

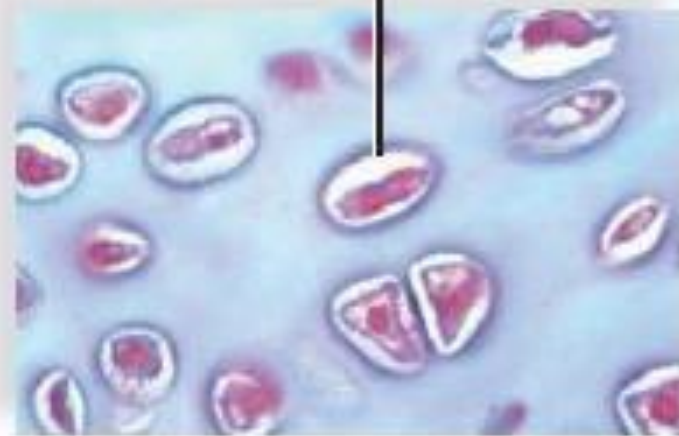

- *New cells arise only from pre-existing cells.*
- Until the nineteenth century, most people believed in spontaneous generation, that is, that nonliving objects could give rise to living organisms. In 1864, the French scientist Louis Pasteur conducted a now-classic set of experiments using bacterial cells. His experiments proved conclusively that spontaneous generation of life from nonlife was not possible

When mice or humans reproduce, a sperm cell joins with an egg cell to form a zygote. This is the first cell of a new multicellular organism. By reproducing, parents pass a copy of their genes onto their offspring. The genes contain the instructions that allow the zygote to grow and develop into the complete organism.

- **Microscopy**

Micrographs are photographs of objects most often obtained by using:

1. Compound light microscope: A *compound light microscope* uses a set of glass lenses and light rays passing through the object to magnify objects. The image can be viewed directly by the human eye.

## 2. Transmission electron microscope:

The *transmission electron microscope* makes use of a stream of electrons to produce magnified images. The human eye cannot see the image. Therefore, **it is projected onto a fluorescent screen or photographic film to produce an image that can be viewed.** The magnification produced by a transmission electron microscope is much higher than that of a light microscope. Also, this microscope has the ability to produce enlarged images with greater detail. In other words, the transmission electron microscope has a higher resolving power—the ability to distinguish between two adjacent points.

### 3. Scanning electron microscope:

A *scanning electron microscope* provides a three dimensional view of the surface of an object. A narrow beam of electrons is scanned over the surface of the specimen, which is coated with a thin layer of metal. The metal gives off secondary electrons, which are collected to produce a television-type picture of the specimen's surface on a screen.

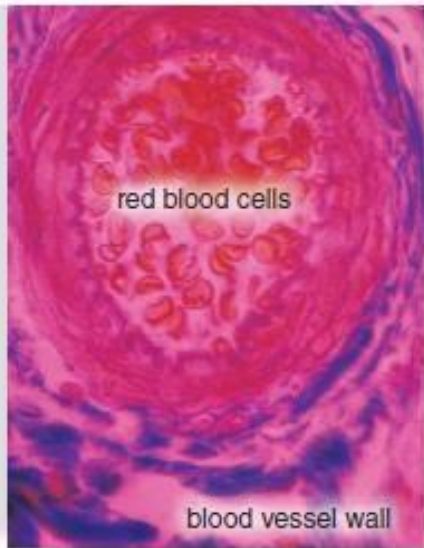

a. Light micrograph

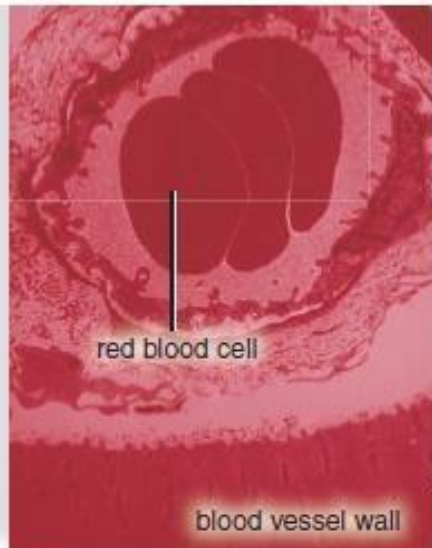

b. Transmission electron micrograph

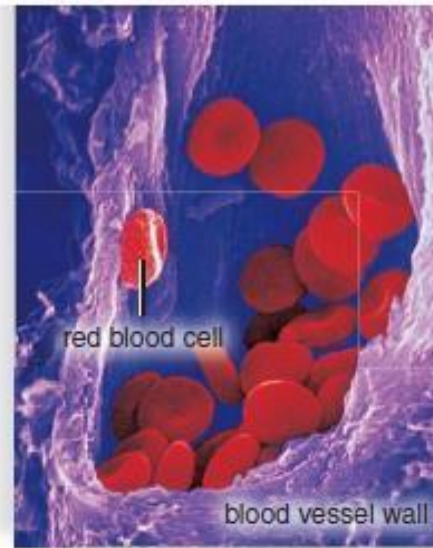

c. Scanning electron micrograph

**Figure** Micrographs of human red blood cells. Each of these micrographs is of a human red blood cell.

**a.** Light micrograph (LM) of many cells in a large vessel (stained). **b.** Transmission electron micrograph (TEM) of just three cells in a small vessel (colored). **c.** Scanning electron micrograph (SEM) gives a three-dimensional view of cells and vessels (colored).



# How Cells Are Organized

Biologists classify cells into two broad categories—the **prokaryotes** and **eukaryotes**. The prokaryotic group includes the bacteria; the eukaryotic group consists of animals, plants, fungi, and some single-celled organisms. Despite their differences, both types of cells have a **plasma membrane**, an outer membrane that regulates what enters and exits a cell. The plasma membrane is a phospholipid bilayer.

All types of cells also contain **cytoplasm**, which is a semifluid medium that contains water and various types of molecules suspended or dissolved in the medium. The presence of proteins accounts for the semi fluid nature of the cytoplasm. The cytoplasm contains **organelles**. Eukaryotic cells have many different types of organelles.

# Internal Structure of Eukaryotic Cells

The most prominent organelle within the **eukaryotic cell** is a **nucleus**, a membrane-enclosed structure in which DNA is found. **Prokaryotic cells** (such as bacterial cells) lack a nucleus . Although the DNA of prokaryotic cells is centrally placed within the cell, it is not surrounded by a membrane.

**Plasma membrane:** outer surface that regulates entrance and exit of molecules

protein

phospholipid

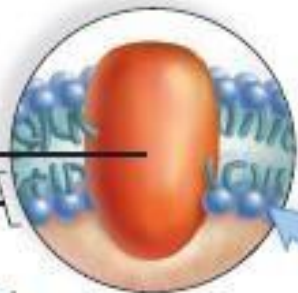

a.



**CYTOSKELETON:** maintains cell shape and assists movement of cell parts:

**Microtubules:** cylinders of protein molecules present in cytoplasm, centrioles, cilia, and flagella

**Intermediate filaments:** protein fibers that provide support and strength

**Actin filaments:** protein fibers that play a role in movement of cell and organelles

**Centrioles:** short cylinders of microtubules of unknown function

**Centrosome:** microtubule organizing center that contains a pair of centrioles

**Lysosome:** vesicle that digests macromolecules and even cell parts

**Vesicle:** membrane-bounded sac that stores and transports substances

**Cytoplasm:** semifluid matrix outside nucleus that contains organelles

**NUCLEUS:**

**Nuclear envelope:** double membrane with nuclear pores that encloses nucleus

**Chromatin:** diffuse threads containing DNA and protein

**Nucleolus:** region that produces subunits of ribosomes

**ENDOPLASMIC RETICULUM:**

**Rough ER:** studded with ribosomes, processes proteins

**Smooth ER:** lacks ribosomes, synthesizes lipid molecules

**Ribosomes:** particles that carry out protein synthesis

**Mitochondrion:** organelle that carries out cellular respiration, producing ATP molecules

**Polyribosome:** string of ribosomes simultaneously synthesizing same protein

**Golgi apparatus:** processes, packages, and secretes modified cell products

b.

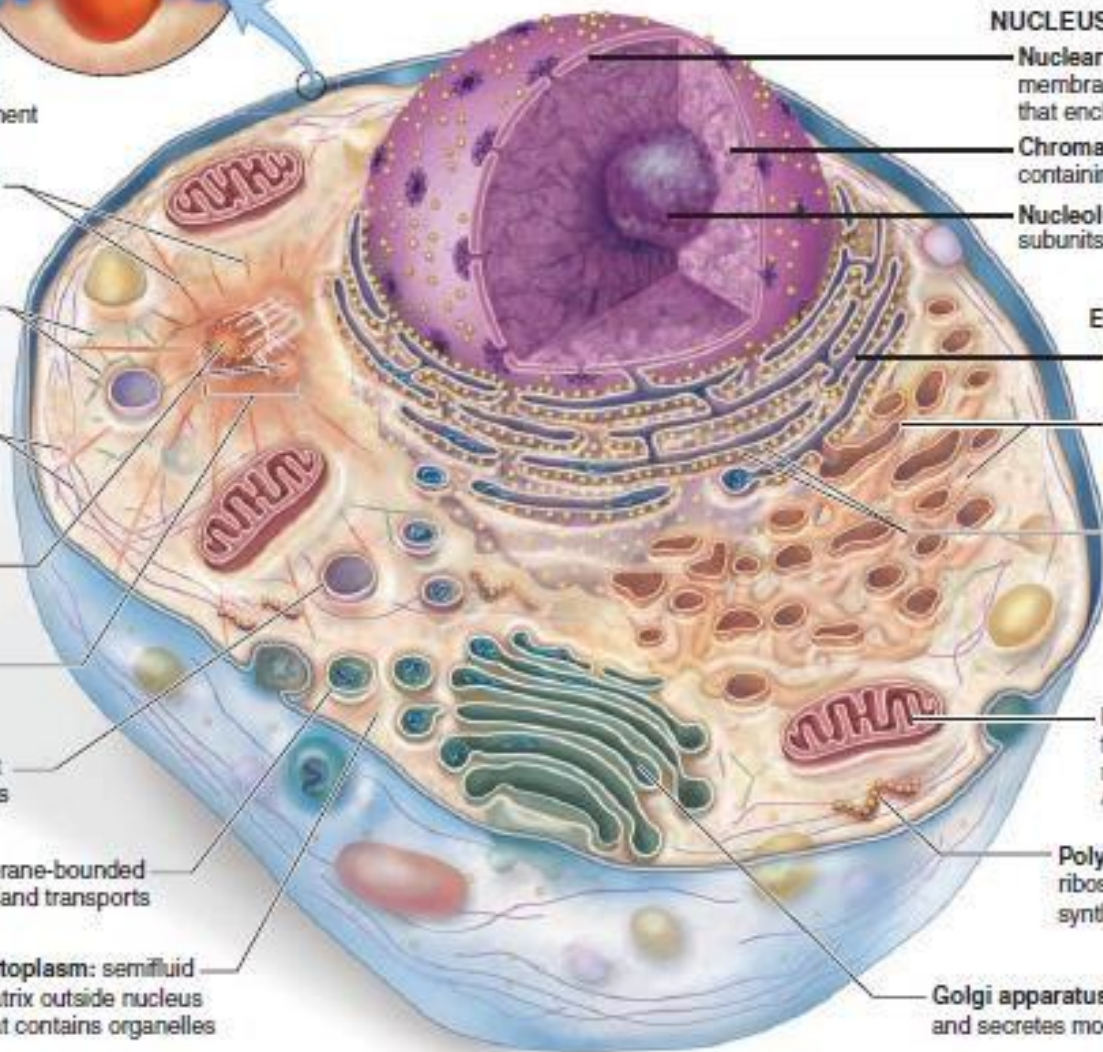

**Figure 3.4** The structure of a typical eukaryotic cell.

# The Plasma Membrane

The plasma membrane is a phospholipid bilayer with attached or embedded proteins. A phospholipid molecule has a polar head and nonpolar tails. When phospholipids are placed in water, they naturally form a spherical bilayer. The polar heads, being charged, are hydrophilic(attracted to water).

They position themselves to face toward the watery environment outside and inside the cell. The nonpolar tails are hydrophobic (not attracted to water). They turn inward toward one another, where there is no water.

# The Plasma Membrane

At body temperature, the phospholipid bilayer is a liquid. It has the consistency of olive oil. The proteins are able to change their position by moving laterally. The **fluid-mosaic model** is a working description of membrane structure. It states that the protein molecules form a shifting pattern within the fluid phospholipid bilayer. Cholesterol lends support to the membrane. Short chains of sugars are attached to the outer surface of some protein and lipid molecules. These are called *glycoproteins* and *glycolipids*, respectively.

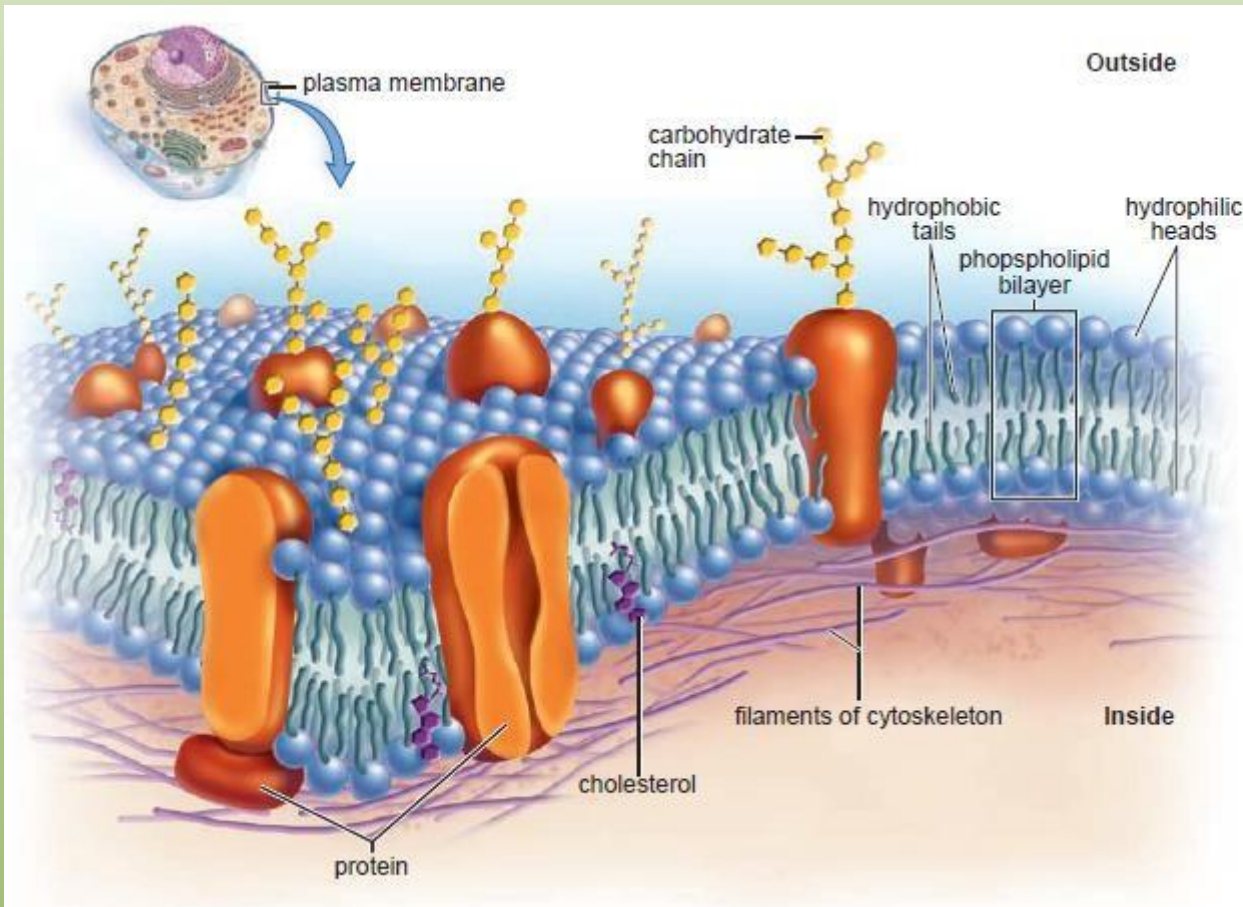

**Figure** Organization of the plasma membrane.

A plasma membrane is composed of a phospholipid bilayer in which proteins are embedded. The hydrophilic heads of phospholipids are a part of the outside surface and the inside surface of the membrane. The hydrophobic tails make up the interior of the membrane. Note the plasma membrane's asymmetry—carbohydrate chains are attached to the outside surface, and cytoskeleton filaments are attached to the inside surface. Cholesterol lends support to the membrane.

# Plasma Membrane Functions

The plasma membrane keeps a cell intact. It allows only certain molecules and ions to enter and exit the cytoplasm freely. Therefore, the plasma membrane is said to be selectively permeable. Small, lipid-soluble molecules, such as **oxygen** and **carbon dioxide**, can pass through the membrane easily. The small size of water molecules allows them to freely cross the membrane by using protein channels called **aquaporins**. Ions and large molecules cannot cross the membrane without more direct assistance.



# PLASMA MEMBRANE

## Diffusion

- Diffusion is the random movement of molecules from an area of higher concentration to an area of lower concentration, until they are equally distributed. Diffusion is a passive way for molecules to enter or exit a cell. No cellular energy is needed to bring it about. e.g. diffusion of gases

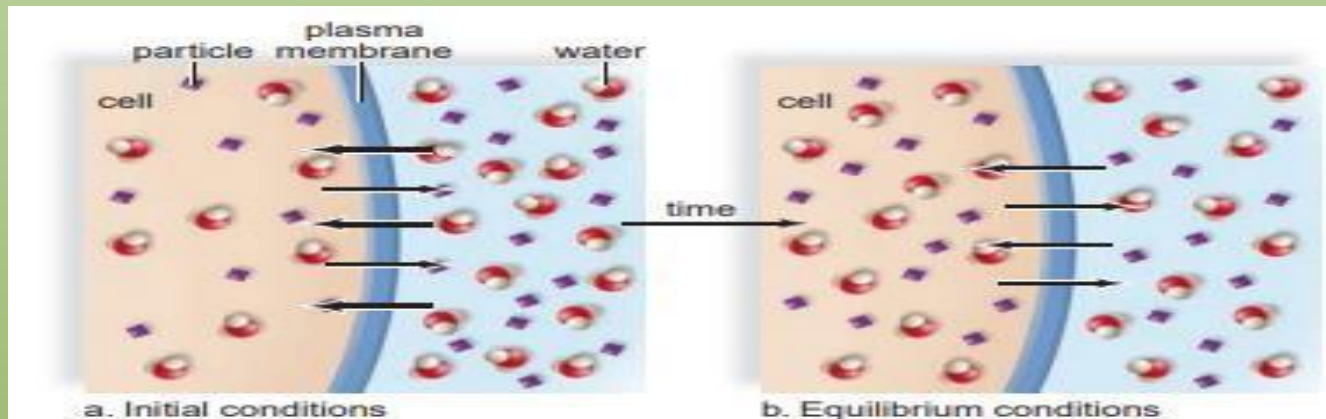

**Figure 3.8** Diffusion across the plasma membrane.

**a.** When a substance can diffuse across the plasma membrane, it will move back and forth across the membrane, but the net movement will be toward the region of lower concentration. **b.** At equilibrium, equal numbers of particles and water have crossed in both directions, and there is no net movement.

# PLASMA MEMBRANE

## Osmosis

- Osmosis is the net movement of water across a semipermeable membrane, from an **area of higher concentration to an area of lower concentration**. The membrane separates the two areas, and solute is unable to pass through the membrane. Water will tend to flow from the area that has less solute (and therefore more water) to the area with more solute (and therefore less water). **Tonicity** refers to the osmotic characteristics of a solution across a particular membrane, such as a red blood cell membrane.

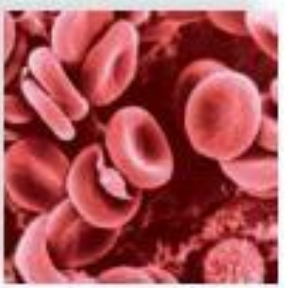

a. Isotonic solution (same solute concentration as in cell)

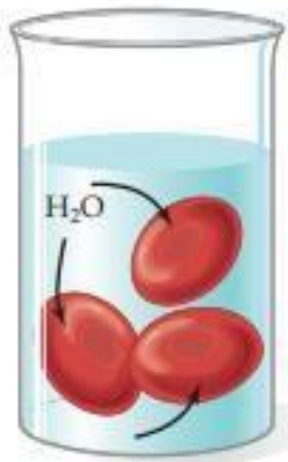

b. Hypotonic solution (lower solute concentration than in cell)

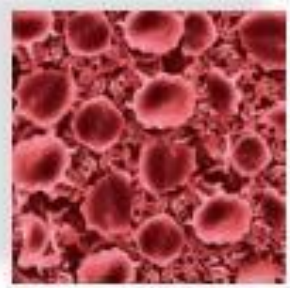
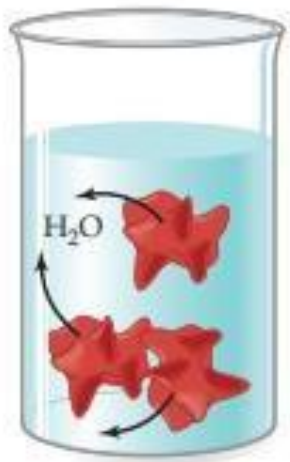

c. Hypertonic solution (higher solute concentration than in cell)

**Figure 3.9** Effects of changes in tonicity on red blood cells. **a.** In an isotonic solution, cells remain the same. **b.** In a hypotonic solution, cells gain water and may burst (lysis). **c.** In a hypertonic solution, cells lose water and shrink (crenation).

# PLASMA MEMBRANE

## Active Transport

- During **active transport**, a molecule is moving from a lower to higher concentration. One example is the concentration of iodine ions in the cells of the thyroid gland. In the digestive tract, sugar is completely absorbed from the gut by cells that line the intestines. In another example, water homeostasis is maintained by the kidneys by the active transport of sodium ions ( $\text{Na}^+$ ) by cells lining kidney tubules. Active transport requires a **protein carrier** and the use of **cellular energy obtained from the breakdown of ATP**. When ATP is broken down, energy is released. In this case, the energy is used to carry out active transport. Proteins involved in active transport often are called **pumps**.

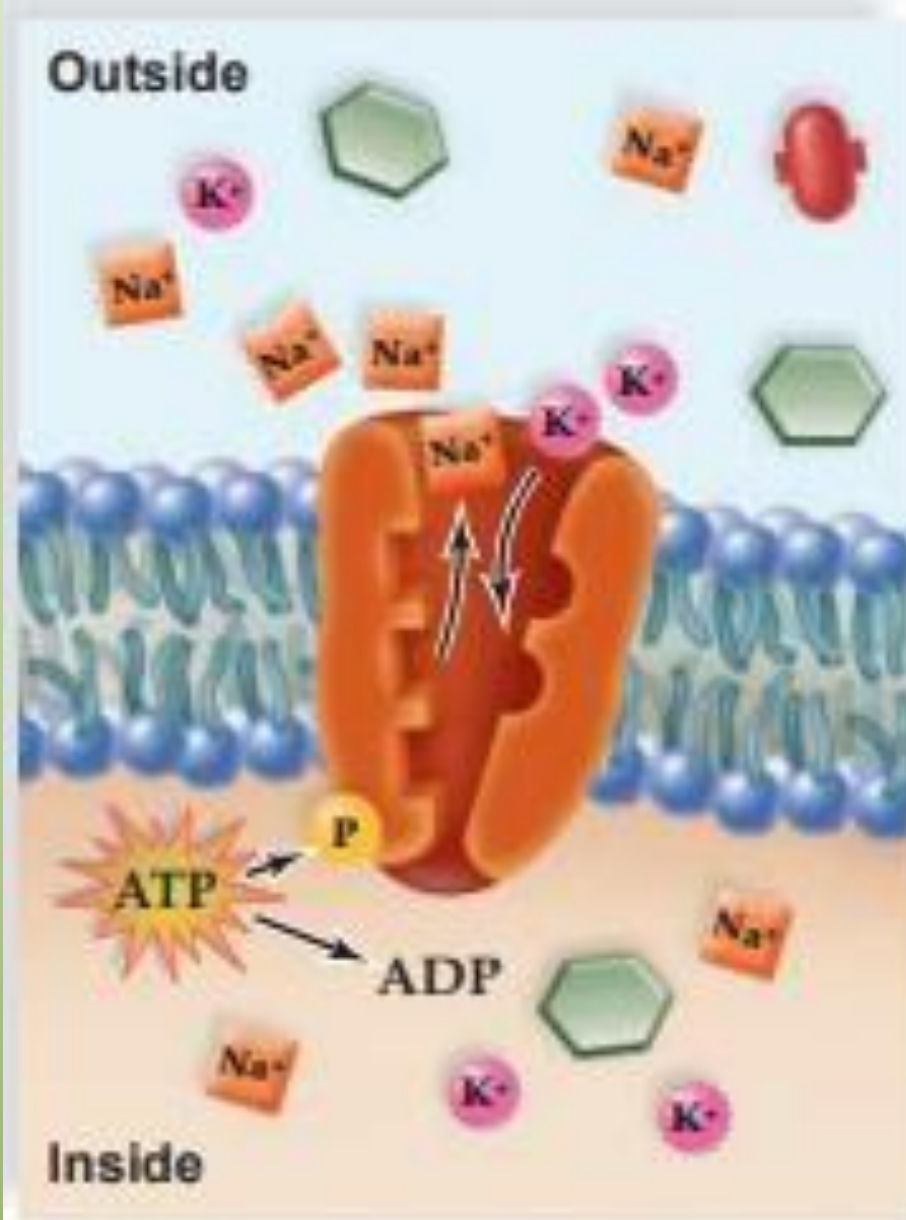

**Figure 3.11** Active transport and the sodium–potassium pump. This is a form of transport in which a molecule moves from low concentration to high concentration. It requires a protein carrier and energy.  $\text{Na}^+$  exits and  $\text{K}^+$  enters the cell by active transport, so  $\text{Na}^+$  will be concentrated outside and  $\text{K}^+$  will be concentrated inside the cell.

# Nucleus

The **nucleus**, a prominent structure in cells, stores genetic information. Every cell in the body contains the same genes. Genes are segments of DNA that contain information for the production of specific proteins. Each type of cell has certain genes turned on and others turned off. DNA, with RNA acting as an intermediary, specifies the proteins in a cell. Proteins have many functions in cells, and they help determine a cell's specificity.

# Nucleus

**Chromatin** is the combination of DNA molecules and proteins that make up the **chromosomes**. Micrographs of a nucleus do show one or more dark regions of the chromatin. These are nucleoli (sing., **nucleolus**), where ribosomal RNA (rRNA) is produced. This is also where rRNA joins with proteins to form the subunits of ribosomes.

# Nucleus

The nucleus is separated from the cytoplasm by a double membrane known as the **nuclear envelope**. This is continuous with the **endoplasmic reticulum (ER)**, a membranous system of saccules and channels. The nuclear envelope has **nuclear pores** of sufficient size to permit the passage of ribosomal subunits out of the nucleus and proteins into the nucleus.



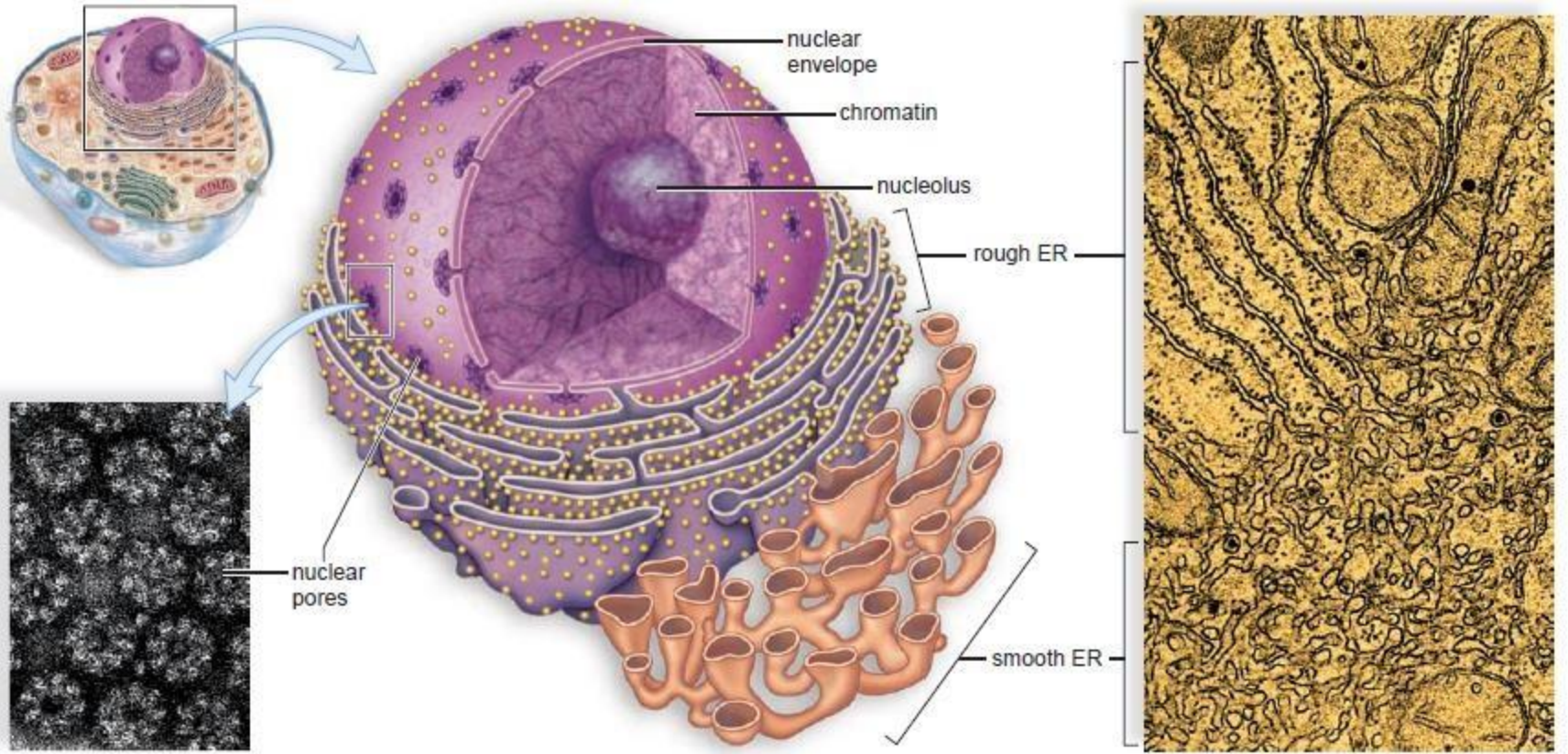

**Figure** The nucleus and endoplasmic reticulum.

# • Ribosomes

**Ribosomes** are organelles composed of proteins and rRNA. Protein synthesis occurs at the ribosomes. Ribosomes are often attached to the endoplasmic reticulum; but they also may occur free within the cytoplasm, either singly or in groups called **polyribosomes**. Proteins synthesized at ribosomes attached to the endoplasmic reticulum have a different destination from that of proteins manufactured at ribosomes free in the cytoplasm.

# The Endomembrane System

The **endomembrane system** consists of

- ❑ the nuclear envelope
- ❑ the endoplasmic reticulum
- ❑ the Golgi apparatus
- ❑ lysosomes
- ❑ and **vesicles** (tiny membranous sacs)

# *The Endoplasmic Reticulum*

- The endoplasmic reticulum has two portions. **Rough ER** is studded with ribosomes on the side of the membrane that faces the cytoplasm.
- **Proteins** are synthesized and enter the ER interior, where processing and modification begin. Some of these proteins are incorporated into membrane, and some are for export.

# *The Endoplasmic Reticulum*

- Smooth ER, continuous with rough ER, does not have attached ribosomes. Smooth ER synthesizes the **phospholipids** that occur in membranes and has various other functions, depending on the particular cell, **In the testes, it produces testosterone.** **In the liver, it helps detoxify drugs.**

# *The Golgi Apparatus*

The **Golgi apparatus** is named for Camillo Golgi, who discovered its presence in cells in 1898. The Golgi apparatus consists of a stack of slightly curved saccules, whose appearance can be compared to a stack of pancakes.

- proteins and lipids received from the ER are modified. For example, a chain of sugars may be added to them. This makes them glycoproteins and glycolipids, molecules often found in the plasma membrane. In all, the Golgi apparatus is involved in processing, packaging, and secretion

# ***Lysosomes***

**Lysosomes**, membranous sacs produced by the Golgi apparatus, contain *hydrolytic enzymes*. Lysosomes are found in all cells of the body but are particularly numerous in white blood cells that engulf disease-causing microbes. When a lysosome fuses with such an endocytic vesicle, its contents are digested by lysosomal enzymes into simpler subunits that then enter the cytoplasm. In a process called **autodigestion**, parts of a cell may be broken down by the lysosomes . Some human diseases are caused by the lack of a particular lysosome enzyme . **Tay–Sachs disease** occurs when an undigested substance collects in nerve cells, leading to developmental problems and death in early childhood.

# The Cytoskeleton, Cell Movement, and Cell Junctions

In the cytoskeleton, **microtubules** are much larger than **actin filaments**. Each is a cylinder that contains rows of a protein called **tubulin**. The regulation of microtubule assembly is under the control of a microtubule organizing center called the **centrosome**. During cell division, microtubules form spindle fibers, which assist the movement of chromosomes.



# The Cytoskeleton, Cell Movement, and Cell Junctions

- **Actin filaments:** made of a protein called actin, are long, extremely thin fibers ,Actin filaments are involved in movement
- **Intermediate filaments:** as their name implies, are intermediate in size between microtubules and actin filaments. Their structure and function differ according to the type of cell.

# Cilia and Flagella

**Cilia** (sing., **cilium**) and **flagella** (sing., **flagellum**) are involved in movement. **The ciliated cells** that line our respiratory tract sweep debris trapped within mucus back up the throat. This helps keep the lungs clean. Similarly, ciliated cells move an egg along the oviduct, where it will be fertilized by **a flagellated sperm cell**.

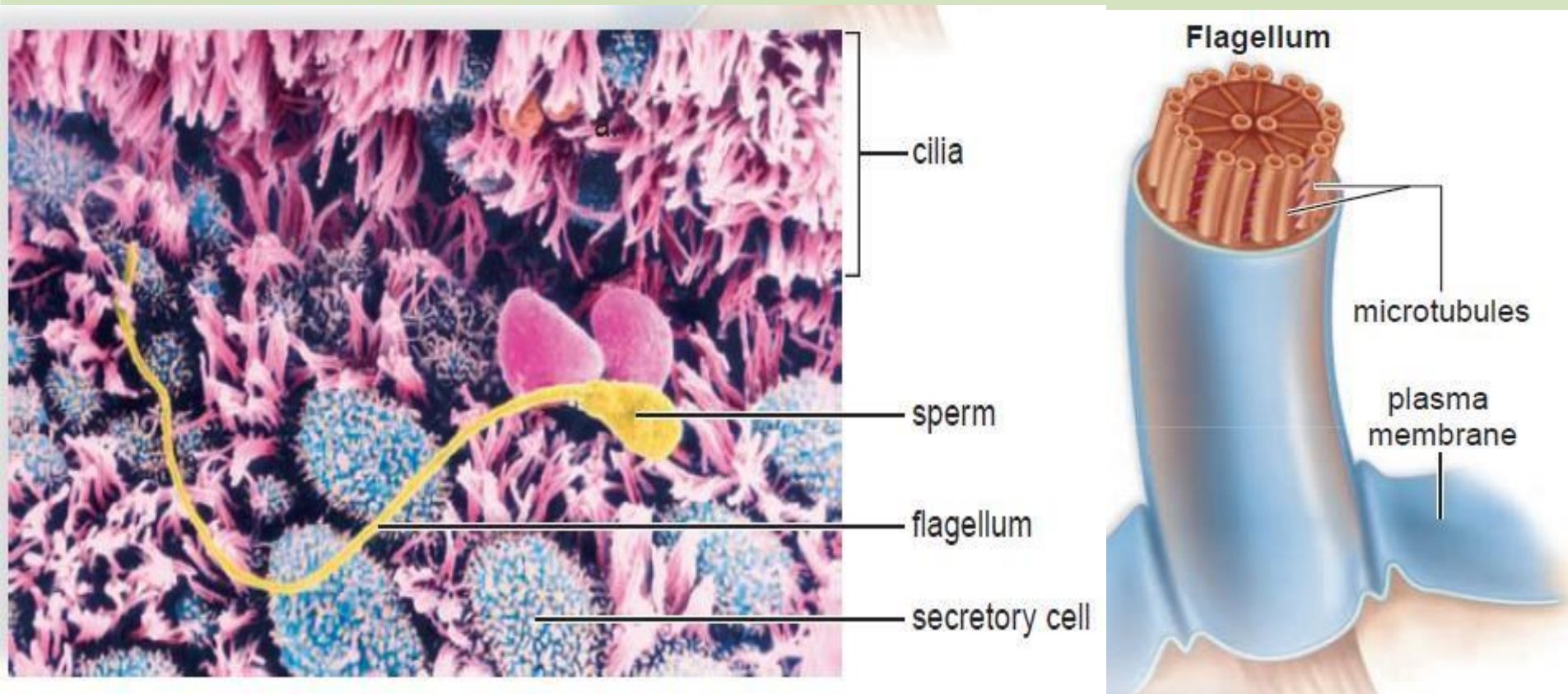

**Figure 3.15** Structure and function of the flagella and cilia. Human reproduction is dependent on the normal activity of cilia and flagella. **a.** Both cilia and flagella have an inner core of microtubules within a covering of plasma membrane. **b.** Cilia within the oviduct move the egg to where it is fertilized by a flagellated sperm. **c.** Sperm have very long flagella.

# Mitochondria and Cellular Metabolism

- ❑ Mitochondria (sing., **mitochondrion**) are often called the powerhouses of the cell. Just as a powerhouse burns fuel to produce electricity, the mitochondria convert the chemical energy of glucose products into the chemical energy of ATP molecules.
- In the process, mitochondria use up oxygen and give off carbon dioxide, Therefore, the process of production ATP is called **cellular respiration**

# Mitochondria

- ❖ The inner membrane is folded to form little shelves called *cristae*. These project into the *matrix*, an inner space filled with a gel-like fluid.
- ❖ The matrix of a mitochondrion contains enzymes for breaking down glucose products. ATP production then occurs at the cristae.
- ❖ Mitochondria are bounded by a double membrane, as a prokaryote would be if taken into a cell by endocytosis. Even more interesting is the observation that mitochondria have their own genes—and they reproduce themselves.<sup>43</sup>



# Human genetics

## Lecture III



**Assist Prof. Dr.Rehab A. H. Al-Baker**

# chromosomes

- ❑ Originated from the Greek word (chroma, colour) and (soma, body)
- ❑ A chromosome is an organized structure of DNA and protein found in cells
- ❑ Genetic information in bacteria is stored as a sequence of DNA bases.
- ❑ In bacteriophages and viruses, genetic information can be stored as a sequences of ribonucleic acid (RNA).
- ❑ Most DNA molecules are double stranded, with complementary bases (A-T; G-C) paired by hydrogen bonding in the center of the molecule. The orientation of the two DNA strands is antiparallel: One strand is chemically oriented in a 5'→3'direction, and its complementary strand runs 3'→5'.



**The complementarity of the bases enables one strand (template strand) to provide the information for copying or expression of information in the other strand (coding strand)**

**The base pairs are stacked within the center of the DNA double helix , and they determine its genetic information. Each turn of the helix has one major groove and one minor groove.**

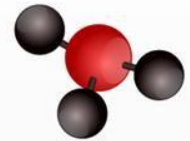
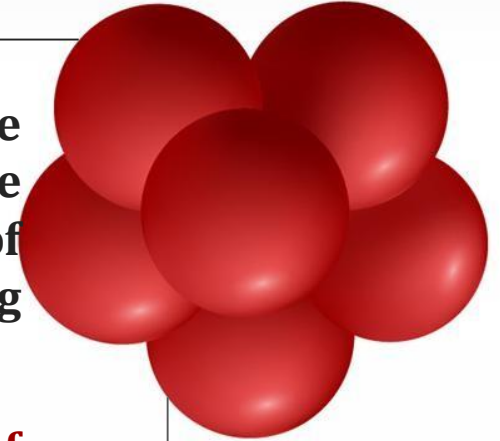



# chromosomes

- ✓ Certain proteins have the capacity to bind DNA and regulate gene expression by interacting predominantly with the major groove, where atoms comprising the bases are more exposed. Each of the four bases is bonded to phospho-2'-deoxyribose to form a **nucleotide**.
- ✓ The length of a DNA molecule is usually expressed in thousands of base pairs, or **kilobase pairs (kbp)**. Whereas a small virus may contain a single DNA molecule of less than 0.5 kbp, the single DNA genome that encodes *Escherichia coli* is greater than 4000 Kbp. **each base pair is separated from the next by about 0.34 nm, or  $3.4 \times 10^{-7}$  m**
- ✓ **RNA most frequently occurs in single-stranded form. The base uracil (U) replaces thymine (T) in DNA, so the complementary bases that determine the structure of RNA are A-U and C-G.** The overall structure of single-stranded RNA molecules is determined by pairing between bases within **the strand-forming loops**, with the result that single-stranded RNA molecules assume a compact structure capable of expressing genetic information contained in DNA.

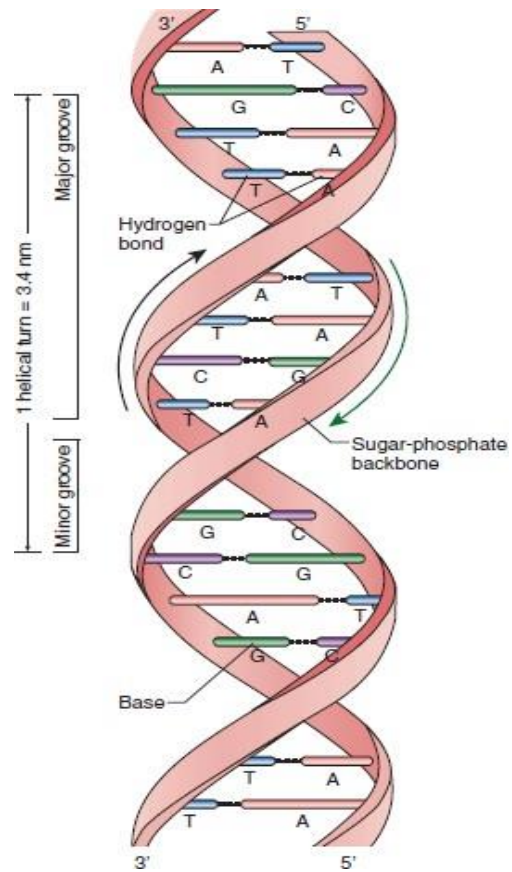

A schematic drawing of the **Watson-Crick** structure of DNA, showing helical sugar-phosphate backbones of the two strands held together by hydrogen bonding between the bases.

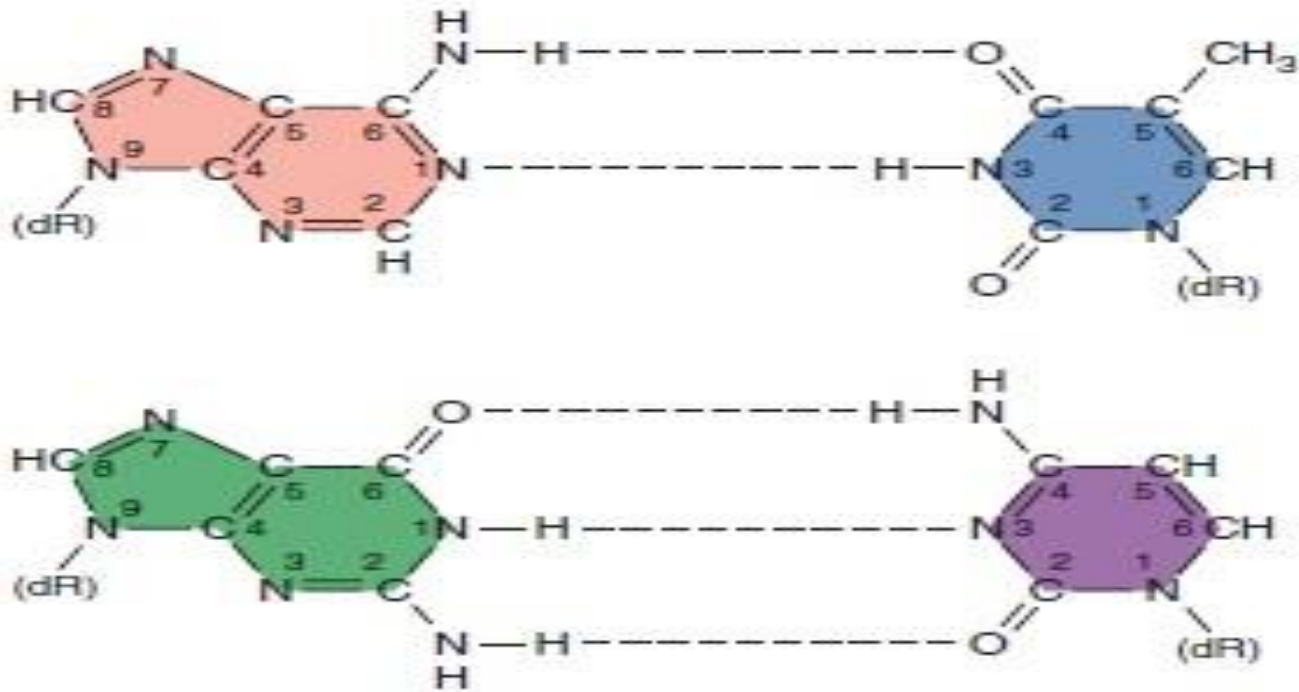

Normal base-pairing in DNA. **Top:** Adenine-thymine (A-T) pairing; **bottom:** guanine-cytosine (G-C) pair. Hydrogen bonds are indicated by *dotted lines*. Note that the G-C pairing shares three sets of hydrogen bonds, but the A-T pairing has only two. Consequently, a G-C interaction is stronger than an A-T interaction. dR, deoxyribose of the sugar-phosphate DNA backbone

**A** human nucleus is only about 5–8  $\mu\text{m}$  long, yet it holds all the chromatin that condenses to form the chromosomes when cells divide, Humans have 46 chromosomes that occur in 23 pairs.

One pair of chromosomes is called the sex chromosomes because this pair contains the genes that control gender. **Males have the sex chromosomes X and Y**, and **females have two X chromosomes**. Twenty-two of these pairs are called autosomes. All of these chromosomes are found in both males and females

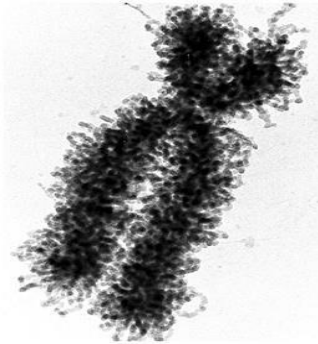

During division of cells

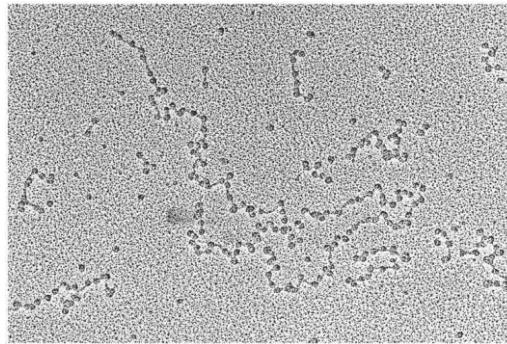

Before division of cells

# Relative position of chromosome in cell

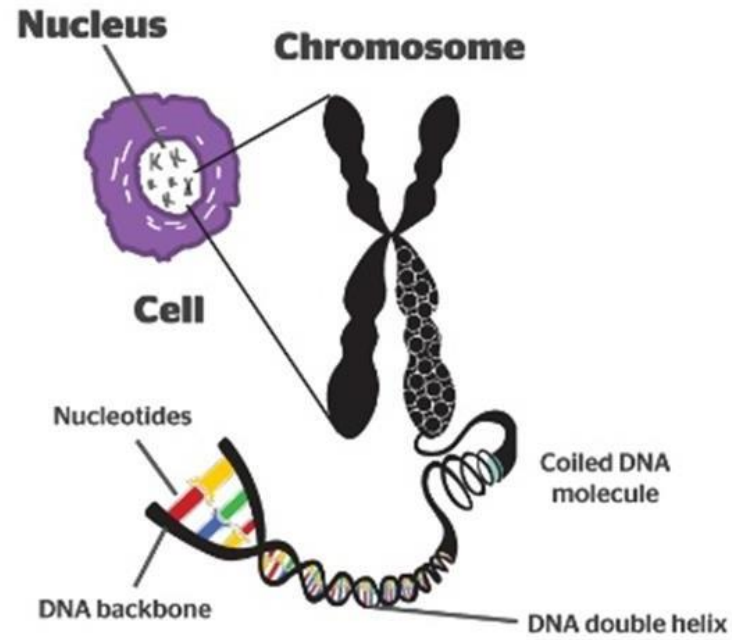

0 S n · chromnosonne nmmnber OE — 0 3 9 X plants and

no Sr.	_____	_____	€Throxw >some nosnber	
			_____	_____
1	<i>Homo sapiens</i>	I-4urrxan	46	23
2	<i>Oryza sativa</i>	Rice	24	12
3	<i>Rattus norvegicus</i>		42	z I
5	<i>Daucus carota</i>	Carrot	20	10
7	<i>Zea mays</i>	Maize	20	10
R	<i>Apis mellifera</i>	Honeybee	32	16
	<i>Musca domestica</i>	Housefly	12	6
10	<i>Felis domesticum</i>	cat	38	19
11	<i>Drosophila melanogaster</i>	Fruit fly	8	4
12	<i>Neurospora Crassa</i>	Breadmold	14	7

# Karyotype

- A karyotype is simply a picture of a person's chromosomes. In order to get this picture, the chromosomes are isolated, stained, and examined under the microscope. Most often, this is done using the chromosomes in the **white blood cells**. A picture of the chromosomes is taken through the microscope. Then, the picture of the chromosomes is cut up and rearranged by the chromosome's size. The chromosomes are lined up from **largest to smallest**. A trained **cytogeneticist** can look for missing or extra pieces of chromosome

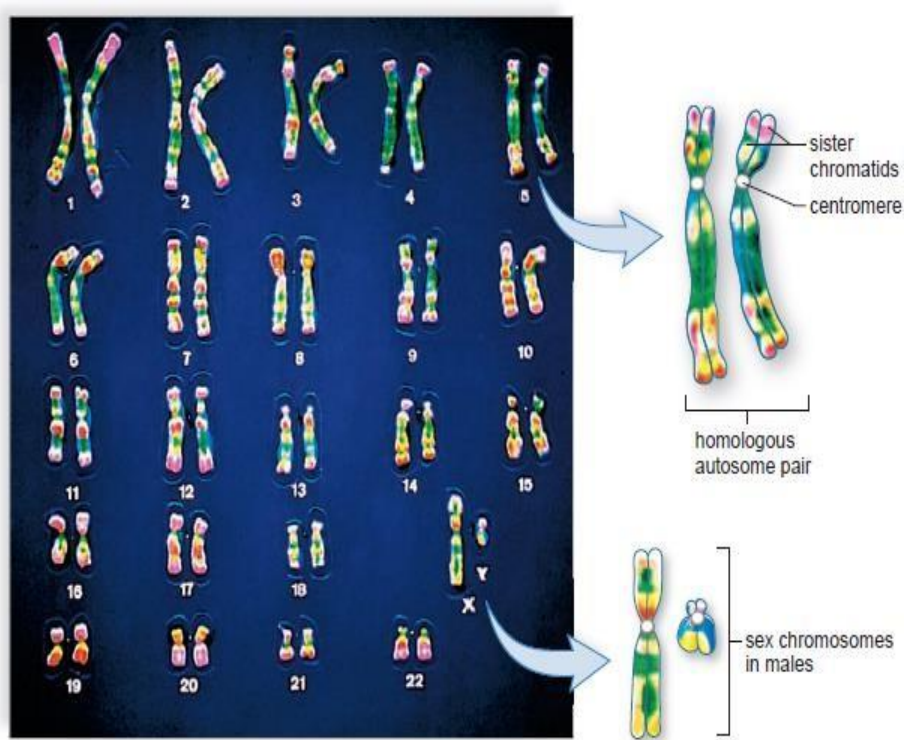

**A karyotype of human chromosomes .** In body cells, the chromosomes occur in pairs. In a karyotype, the pairs have been numbered and arranged by size from largest to smallest. These chromosomes are duplicated, and each one is composed of two sister chromatids.



# Chromosomes Structure



- Centromere
- p arm (petit)
- q arm (queue)
- Telomeres

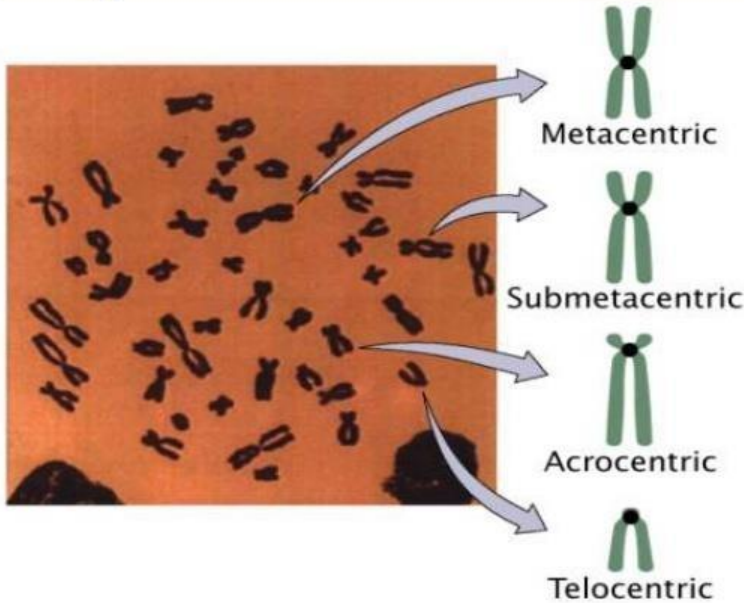
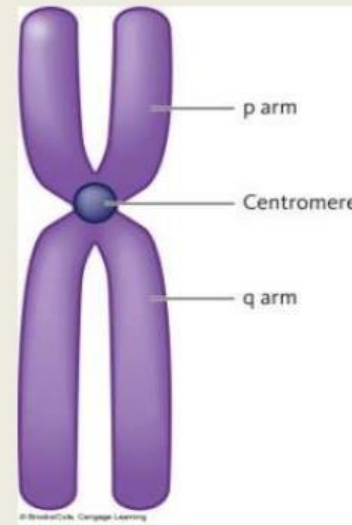

## TYPES OF CHROMOSOMES



There are four basic types of chromosomes seen during anaphase.

These are:

### 1. **TELOCENTRIC:**

–No P arm, centromere is on the end

### 2. **ACROCENTRIC:**

–very small P arm, centromere is very near to the end

### 3. **SUB-METACENTRIC:**

–P arm just a little smaller than Q arm; centromere is in the middle

### 4. **METACENTRIC:**

P and q arms are exactly the same length, centromere is in exact middle of chromosome

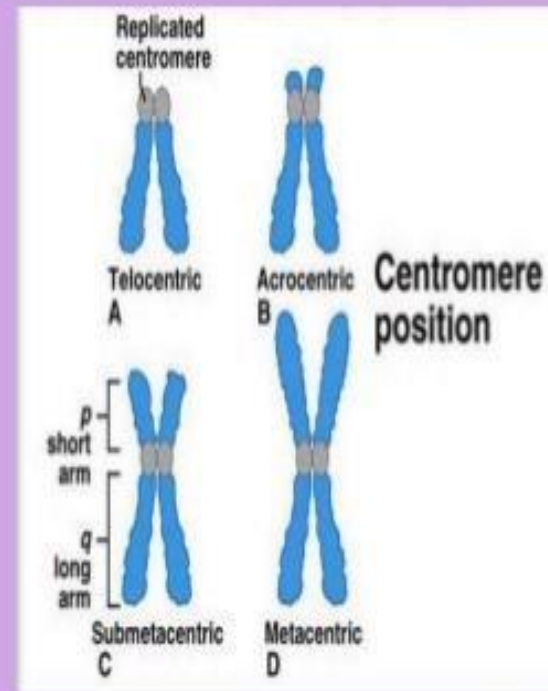

**Chromosomal  
Aberrations**

**Numerical**  
(change in chromosomes NO.)

**Structural**  
(Change in chromosome  
structure)

# Numerical aberrations

```
graph TD; A([Numerical aberrations]) --> B([Monosomy: Loss of single chromosome]); A --> C([Trisomy: Gain of homologous chromosomes]);
```

**Monosomy:** Loss of single chromosome

**Trisomy:** Gain of homologous chromosomes



**Down's syndrome:** Trisomy 21



**Turner syndrom:** Loss of sex chromosome.

# Mutation

- ✓ **Mutation** is defined as an alteration in the original nucleotide sequence of a gene or genes within an organism's genome; that is, a change in the organism's genotype.
- ✓ This alteration may involve a single DNA base in a gene, an entire gene, or several genes.
- ✓ Mutational changes in the sequence may arise spontaneously, perhaps by an error made during DNA replication.
- ✓ Alternatively, mutations may be induced by mutagens (i.e., chemical or physical factors) in the environment or by biologic factors, such as the introduction of foreign DNA into the cell.
- ✓ Alterations in the DNA base sequence can result in changes in the base sequence of mRNA during transcription. This, in turn, can affect the types and sequences of amino acids that will be incorporated into the protein during translation

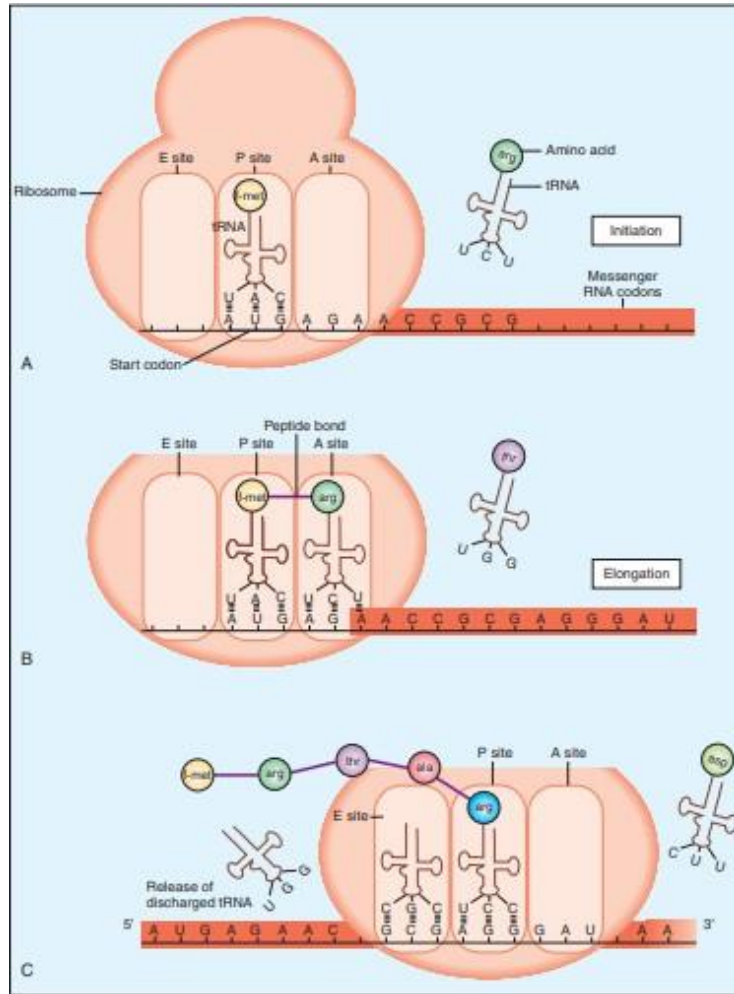

• **Figure 2-6** Overview of translation in which mRNA serves as the template for the assembly of amino acids into polypeptides. The three steps include initiation (**A**), elongation (**B** and **C**), and termination (not shown).

# MUTATION AND GENE REARRANGEMENT

- ✓ The mutations include **base substitutions**, **deletions**, **insertions**, and **rearrangements**.
- ✓ Occurrence of a mispaired base is minimized by enzymes associated with **mismatch repair**, a mechanism that essentially proofreads a newly synthesized strand to ensure that it perfectly complements its template.
- ✓ **Rearrangements** are the result of deletions that remove large portions of genes or even sets of genes



# Mutagens



```
graph TD; A([Mutagens]) --> B([Physical Mutagens]); A --> C([Chemical Mutagens]);
```

## Physical Mutagens

damage DNA by linking neighboring thymine bases to form dimers.

## Chemical Mutagens

may act by altering either the chemical or the physical structure of DNA. Reactive chemicals alter the structure of bases in DNA. For example, nitrous acid ( $\text{HNO}_2$ ) substitutes hydroxyl groups for amino groups.

# Chromosomes

- ✓ Our DNA is distributed among 46 chromosomes within the nucleus. The majority of the cell types in the body have 46 chromosomes. Ordinarily, when a cell divides by a process called **mitosis**, the new cells also have 46 chromosomes. Mitosis is **duplication division**. In the life cycle of a human being, mitosis is the type of cell division that takes place during growth and repair of tissues.

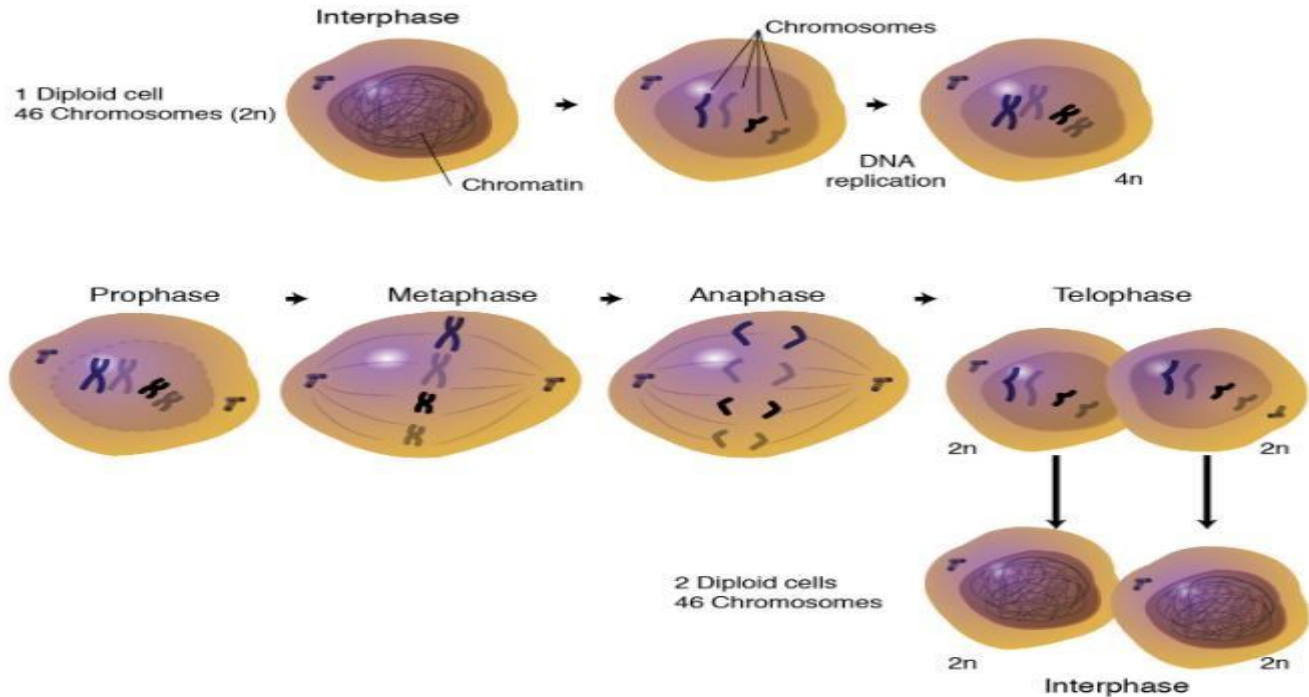

# Chromosomes

- In addition to mitosis, human cells undergo a type of cell division called meiosis, which is **reduction division**.
- Meiosis takes place only in the testes of males during the production of sperm and in the ovaries of females during the production of eggs.
- During meiosis, the chromosome number is reduced from the normal 46 chromosomes, called the diploid or  $2n$  number, down to 23 chromosomes, called the haploid or  $n$  number of chromosomes.
- Meiosis requires two successive divisions, called **meiosis I** and **meiosis II**.
- The flagellated sperm is small compared to the egg. It is specialized to carry only **chromosomes** as it swims to the egg. The egg is specialized to await the arrival of a sperm and to provide the new individual with **cytoplasm** in addition to **chromosomes**. The first cell of a new human being is called the zygote. A sperm has 23 chromosomes and the egg has 23 chromosomes, so the zygote has 46 chromosomes altogether.
- Without meiosis, the chromosome number in each generation of human beings would double, and the cells would no longer be able to function

# Meiosis

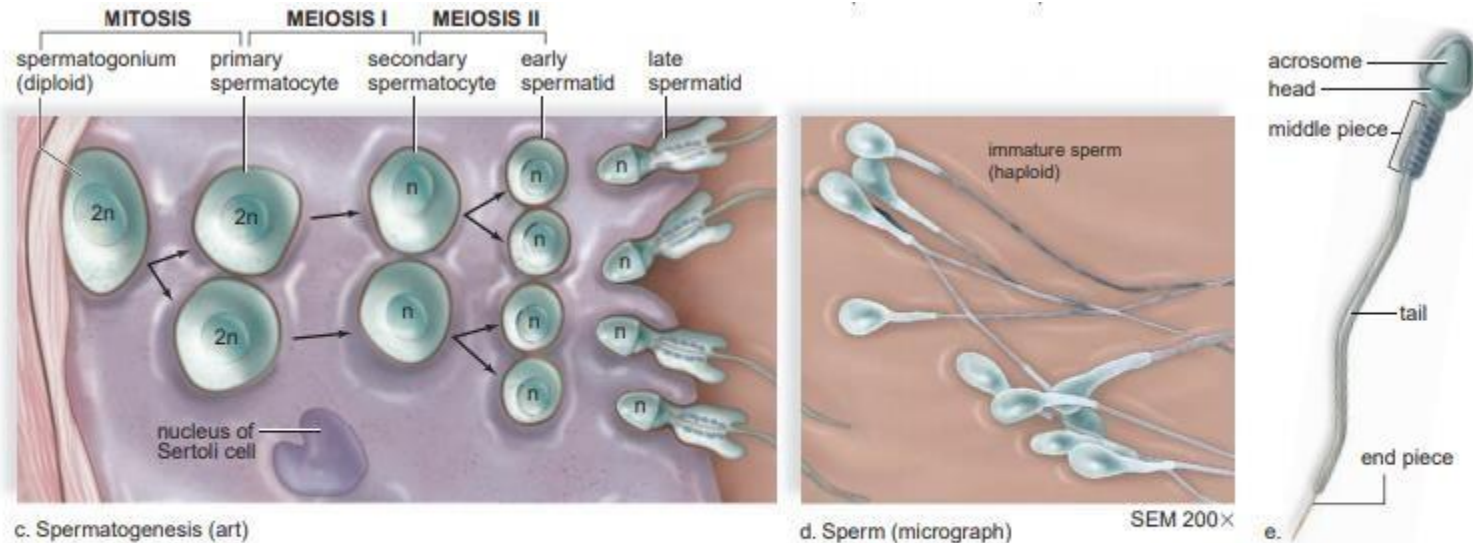

**Figure 16.4** Spermatogenesis produces sperm cells.

**a.** The lobules of a testis contain seminiferous tubules. **b.** Electron micrograph of a cross section of the seminiferous tubules, where spermatogenesis occurs. Note the location of interstitial cells in clumps among the seminiferous tubules. **c.** Diagrammatic representation of spermatogenesis, which occurs in wall of tubules. **d.** Micrograph of sperm. **e.** A sperm has a head, a middle piece, and a tail. The nucleus is in the head, capped by the enzyme-containing acrosome.

# Chromosomes



## What types of cells do not have 46 chromosomes?

In humans, the cell types that do not have the standard 23 pairs of chromosomes are the red blood cells and the cells of the liver. that red blood cells lack a nucleus; therefore, they do not have any chromosomes. Cells in the liver, called **hepatocytes**, typically have more than 3 copies of each chromosome (giving them 69 or more chromosomes). This condition is called **polyploidy**, and it is believed to provide the liver with its ability to degrade toxic compounds.



# Glossary

- **Allele:** Alternative form of a gene; alleles occur at the same locus on homologous chromosomes.
- **Gene:** Unit of heredity existing as alleles on the chromosomes; in diploid organisms, typically two alleles are inherited—one from each parent.
- **Apoptosis :** Programmed cell death involving a cascade of specific cellular events leading to death and destruction of the cell.
- **DNA (deoxyribonucleic acid)** Nucleic acid polymer produced from covalent bonding of nucleotide monomers that contain the sugar deoxyribose; the genetic material of nearly all organisms.
- **chromatin** (kroh-muh-tin) Network of fine threads in the nucleus composed of DNA and proteins.
- **chromosome** (kroh-muh-som) Chromatin condensed into a compact structure.
- **Phenotype**-----eye color in human, antibiotic resistance in bacteria.
- **Genotype**----- alteration in the DNA sequence, within a gene or within the organization of

# Lethal genes

- ❑ Genes which result in the reduction of viability of an individual or become a cause for death of individuals carrying them are called as lethal genes.
- ❑ Certain genes are absolutely essential for survival. Mutation in these genes creates lethal allele

# TYPES OF LETHAL ALLELES

Lethal alleles fall into four categories.

1. **Early onset-** lethal alleles which result in death of an organism at early stage of life, for example, during embryogenesis.
2. **Late onset-** lethal allele which kills organism at their final stage of life are known as late onset allele.
3. **Conditional** - lethal allele which kill an organism under certain environmental conditions only. e.g., some temperature sensitive alleles kill organisms only at high temperature.
4. **Semi lethal** – Lethal allele which kill only some individuals of the population but not all are know as semi lethal



# Sickle Cell Disease

## What is sickle cell disease?

- Sickle cell disease (SCD) is a group of inherited red blood cell disorder.
- Healthy red blood cells are round and they move through small blood vessels carrying oxygen to all parts of the body.
- In sickle cell disease ,the red blood cells become hard and sticky and look like a C-shaped farm tool called a sickle.