



Tunnel Construction
and
Tunneling Methods
Pipe jacking Method

by

Dr. Azealdeen Salih Al-Jawadi

Pipe jacking Method

Pipe Jacking is the **oldest method of trenchless technology**. Pipes are pushed through the ground behind the shield using **powerful jacks**. Simultaneously **excavation takes place within the shield**. This process is continued until the pipeline is completed. The method provides a **flexible, structural, watertight, finished pipeline** as the tunnel is excavated.

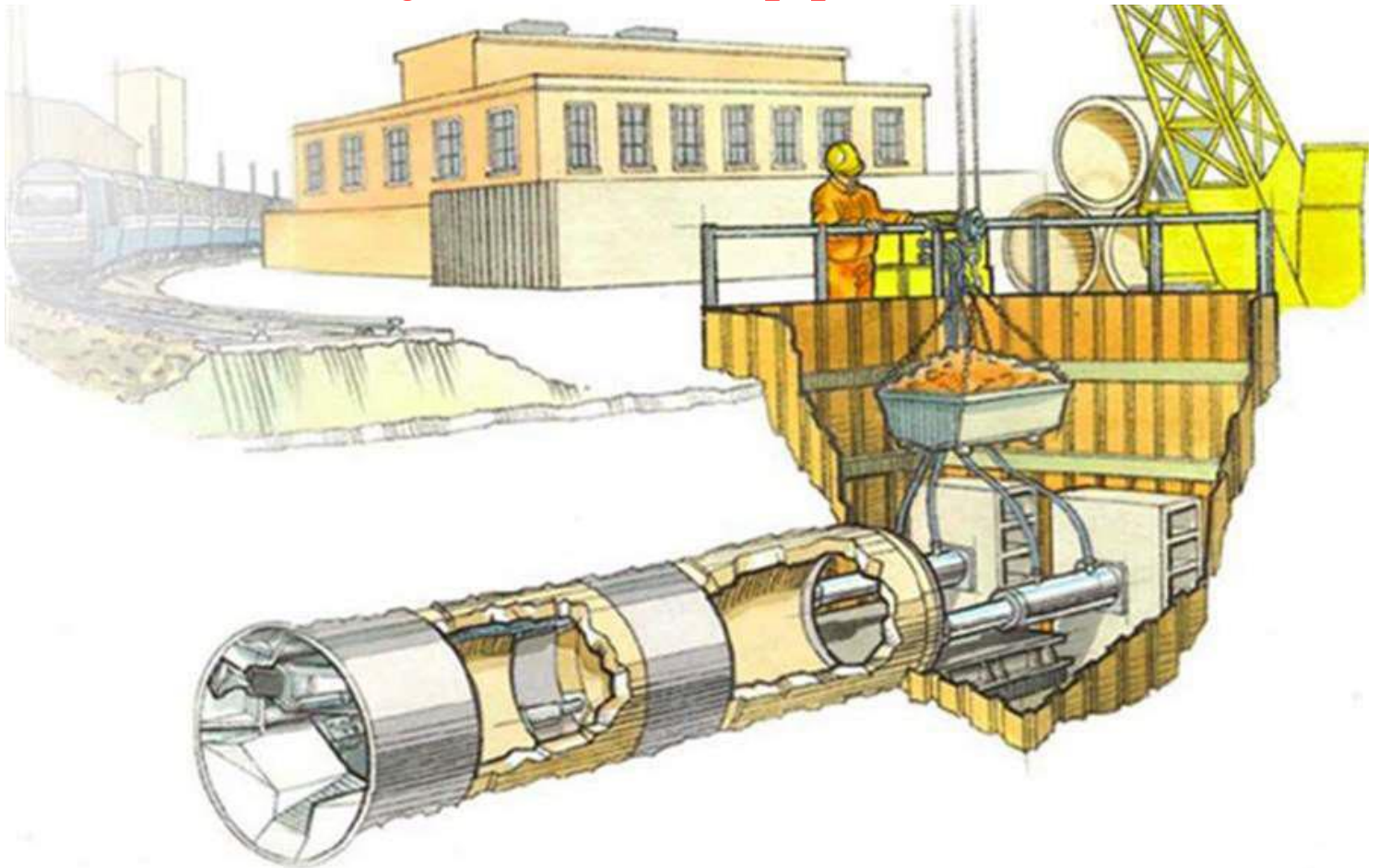

Pipe jacking Method

This method can be used for the installation of pipes from 150 mm to 4 m diameter, or box section up to 7 x 4 m, but it is mainly employed on the larger diameter pipes of over 1 m.

This method is very suitable for installing services under roads and railway embankments without creating disturbance to traffic.

The method consists of forming pits at both ends of the proposed tunnel. A thrust wall is constructed to provide jacking reaction and pipe segments are jacked into the soil.

For small diameter pipes, bullet-shaped solid metal heads are fixed to the leading end of the pipe, which is jacked into the ground displacing the earth.

For tunnels of diameter 1 m or above, the leading pipe is fitted with a steel shield to aid the driving process. The shield provides protection under which the workers excavate the tunnel face. New pipe segments are added from the starting pit and jacked forward one by one until the pipe length reaches the opposite pit.

Schematic representation of a micro-tunneling operation in an inner-city area, showing a launch and reception shaft, using pipe jacking as a method to install the support elements.

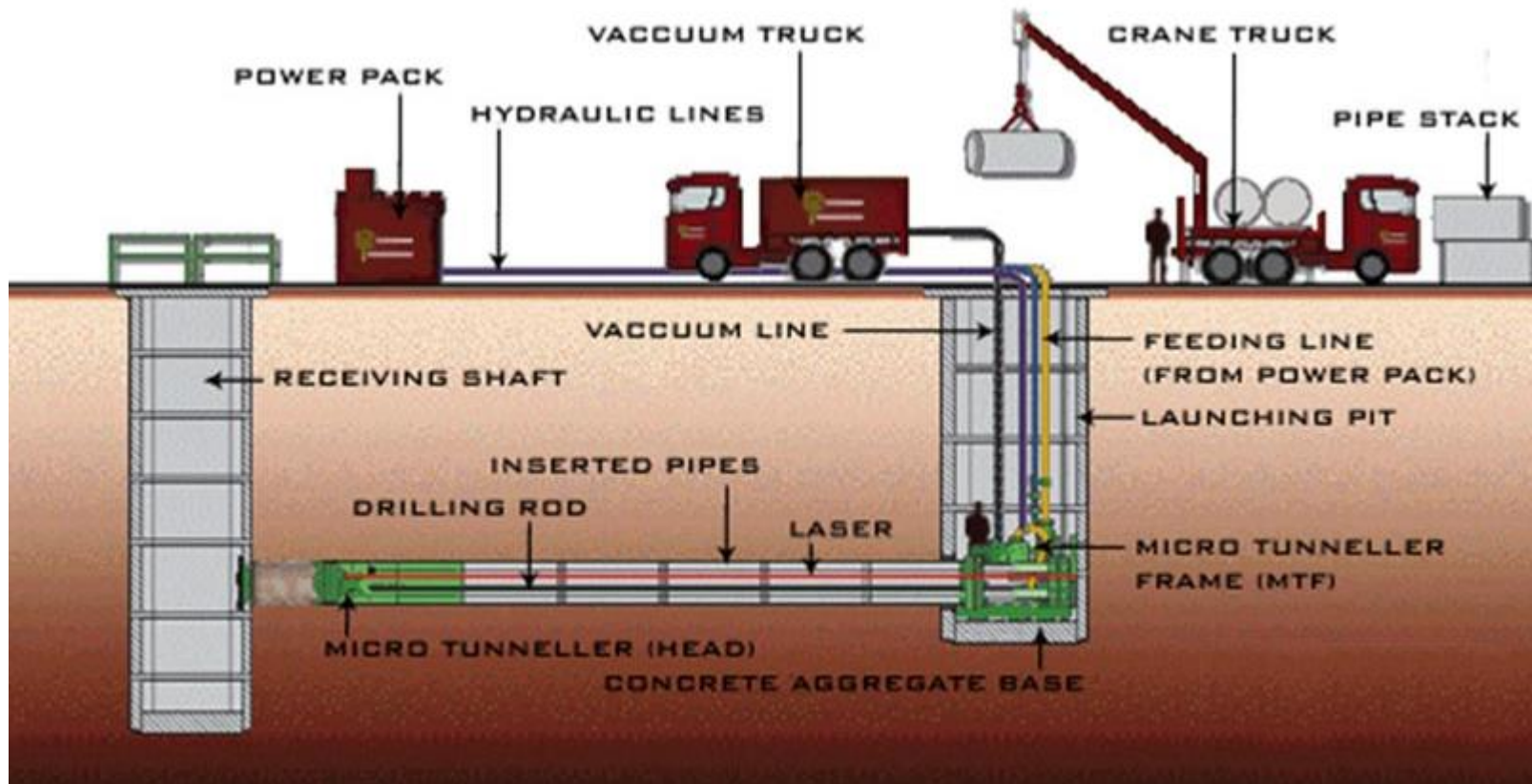

For large diameter pipes or for long pipes, the friction will be very great and it creates problems in providing suitable jacking reaction. A method to counteract the friction is the introduction of **intermediate jacks**. The intermediate jacks are fixed on steel sleeves which are installed at suitable intervals along the pipe length. The line is then jacked forward in a caterpillar fashion. In addition, **bentonite slurry** can be introduced from the rear of the driving shield as lubricant to reduce the friction.

Hydraulic Jacks at Starting Pit



Intermediate Jacks

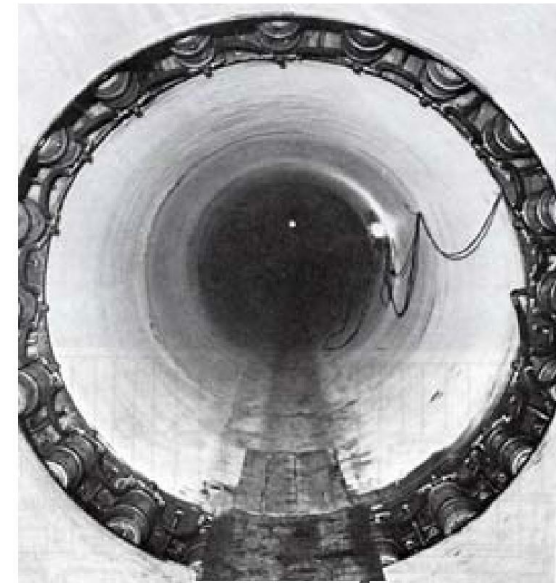

Method of operation of an inter jacking station. In phase 1 the cylinders of both inter jacking stations are retracted. In phase 2 the cylinders of inter jacking station C are extended so that TBM D moves forwards. In phase 3 the cylinders of inter jacking station B are extended and the cylinders of inter jacking station C are retracted to the same degree. In phase 4 the cylinders in the starting pit are extended in order to compress inter jacking station B. During phases 2 to 4 the TBM remains stationary

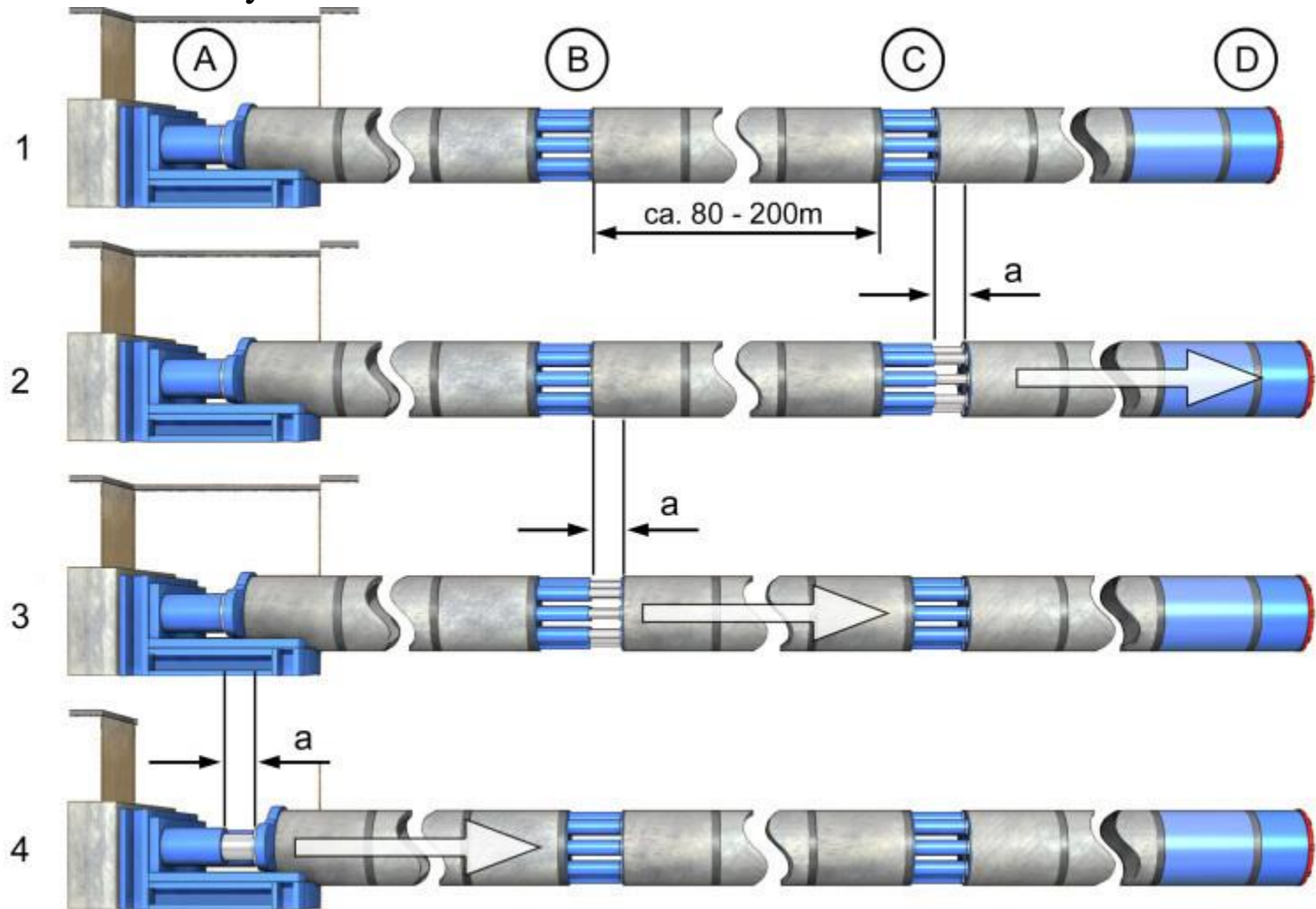

Equipments and components

- **Jacking Pit**

Jacking pit size is function of length of pipe segments, pipe diameter, shield dimensions, thrust wall design, jack size, pressure rings and guide rail systems. Pit should be shored using timber or steel piling. Placement of concrete slab on the floor is recommended.

- **Jack**

Number and capacity of jack is a function of pipe size, length, skin friction, intermediate jacks etc. It is suggested to provide even number of jacks.

- **Pipe**

Pipe should be light weighted, smooth and strong enough to withstand all the forces.

- **Thrust Ring**

Thrust ring distributes force from jack head to pipe edges equally. A spacer is optional.

- **Thrust wall**

Thrust wall is provided behind the jack to transfer back thrust of jack to earth and preventing jack to sink.

- **Lubricant**

Lubrication is provided at outer edges of pipe using lubricant injection ports at proper interval.

- **Intermediate Jack**

Intermediate jack is provided in between the entry and exit shaft. Number of intermediate jack depends on pipe length and jack capacity. Intermediate jack must match pipe diameter.

- **Cutting-head**

Cutting-head or cutter is located at the front of pipe line. It cuts down the soil ahead using mechanical motion into smaller fragments.

- **Pressure Transfer Ring**

Pressure transfer ring is used in between of two pipe at joints, it distribute the pressure to succeeding pipe equally. It is made either of cork or synthetic material.

Classification on basis of pipe material



(a) Reinforced Concrete



(b) Vitrified Clay



(c) Ductile Iron



(d) Fibreglass



(e) Steel



(f) Composite

Classification on basis of Cutter-head



Source: <http://rightofway.transportation.org>

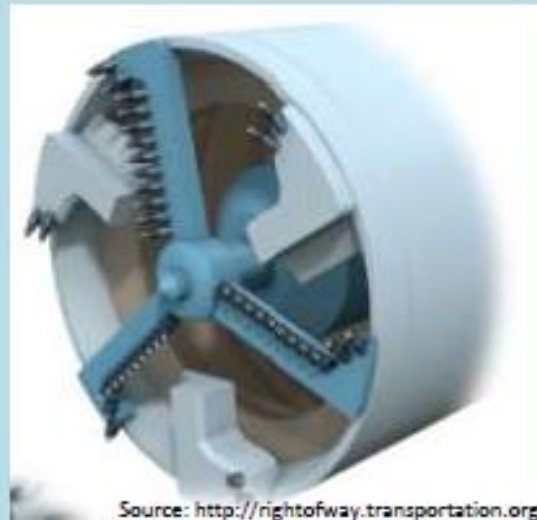

Source: <http://rightofway.transportation.org>



Source: <http://rightofway.transportation.org>

(a) Open Face Cutter Booms

(b) Tunnel Boring Machine

(c) Earth Pressure Balance



Source: <http://rightofway.transportation.org>

(d) Backacters

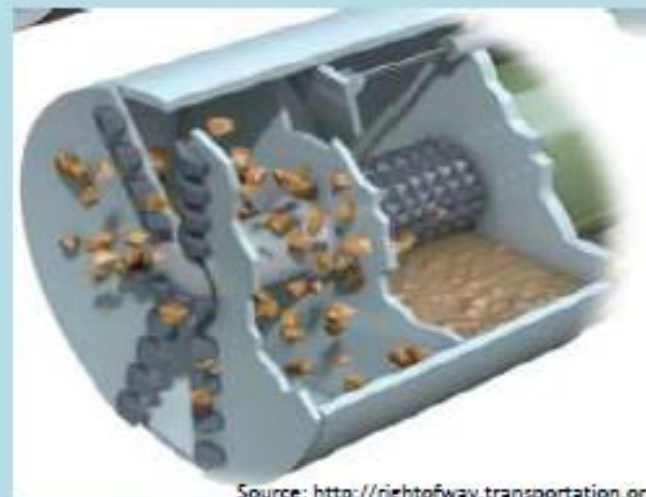

Source: <http://rightofway.transportation.org>

(e) Pressurized Slurry

There are mainly three methods of excavation carried out, which are chosen based on the soil conditions. The first method is **hand mining**, which is the simplest method of all the methods available for excavation. This method makes use of picks, shovels, or any pneumatic hand tools. This method proceeds with the help of a protective shield, that provides face stability during excavation. The method is simple and is helpful when the site consists of varying soil conditions. But this method is time-consuming. Another method is **open-face mechanical excavation**, which is quite faster than hand mining, as it uses mechanical devices. Here also, shields are provided, with power excavation devices. The shields provide access to the front face if any adjustments have to be made, which cannot be done manually under unexpected situations. The third method is **Tunnel Boring Machine (TBM)**, which employs rotary cutters or disk cutters that are driven either hydraulically or electrically. The most improved version of TBM makes use of a pressure chamber. This method has a high cost and limited access. This method is restricted to circular tunnels.

Classification on basis of excavation technique



(a) Manual Excavation



(b) Machine Excavation



(c) Conveyor belt Excavation

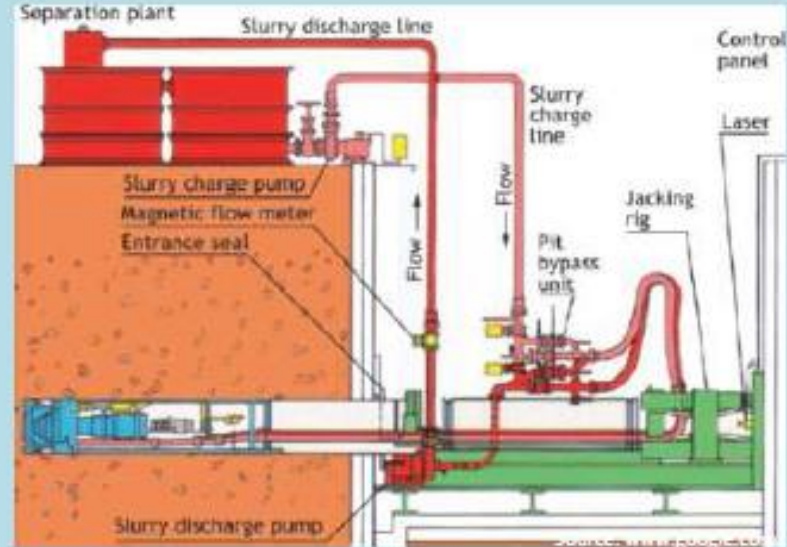

(d) Slurry Excavation

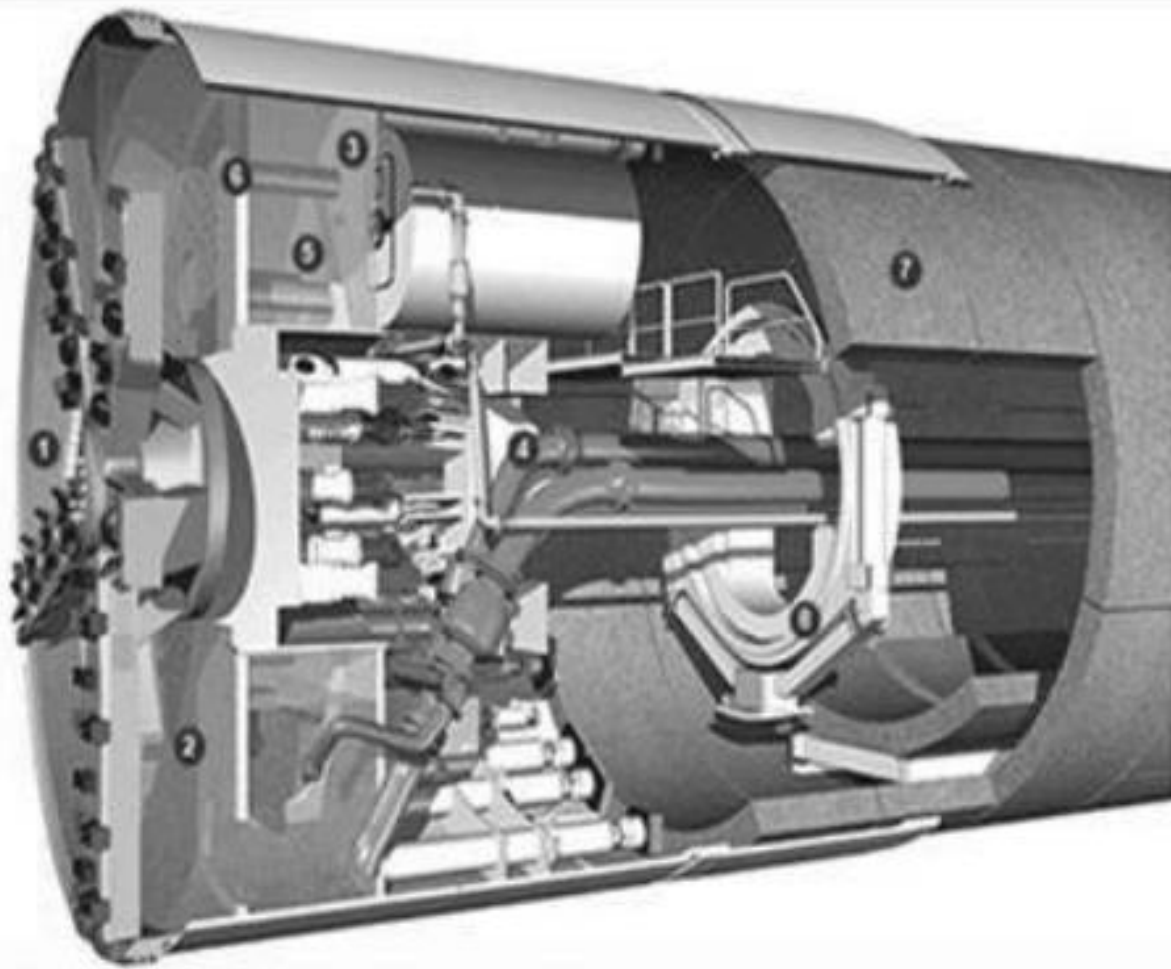

Slurry Components

1 Cutting Head

2 Excavation Chamber

3 Bulkhead

4 Slurry feed line

5 Air Cushion

6 Wall

7 Segmental Lining

8 Segment

Removal of Spoil

Based on space, the method of excavation conducted and the total tunnel length, the best spoil removal system is chosen.

The most common method used is mentioned below:

- Slurry systems
- Auger systems
- Vacuum extraction systems
- Belt or chain conveyors
- Wheeled cart or skips
- Positive displacements pumps

Control of line and grade

The control is mainly done with the help of **theodolite** and **laser systems**. The current position of the tunnel systems can be estimated with the help of theodolite. The laser system shows any kind of variation in already set alignment. The **gyroscope** is a higher sophisticated control device used mainly in curved tunneling. During the excavation, the change in direction is carried out by applying different forces to the jacking cylinders.

Advantages:

- It avoids the excavation of trenches.
- Quick set-up, timely finish of projects.
- Good quality control and good grade of pipe used.
- Can be remotely operated.
- Versatile in various ground conditions.
- Cost efficient for large length pipe.
- Small surface settlements.
- Reduces disruption to existing services.
- Environment friendly.
- Less spoil.

Disadvantages:

- Costly for small lengths.
- Skilled personal is required.
- Dewatering of tunnel path is usually required.
- Not feasible for nature of soil changes drastically.
- Hard rock/Bed rock or very big boulders should not be present in the path line.

A large dam structure with a tunnel entrance and a reservoir in the foreground. The dam is made of concrete and has a large circular opening on the left side. The water in the reservoir is a deep green color. The background shows a steep, rocky hillside.

Thank You